



Radio Replacement Interface with Steering Wheel Control Retention
with Dash Kit for FORD, LINCOLN & MERCURY

PRODUCT FEATURES:

- Retains factory features with an aftermarket radio.
- Retains factory-installed Subwoofer.
- Retains Steering Wheel Controls via built-in, pre-programmed interface.
- With navigation outputs (Reverse gear, Illumination and Speed signal).
- Provides Accessory Power (2A MAX).
- Includes dash kit (double DIN or single DIN with pocket).

PARTS INCLUDED:



SWRFD-60L MODULE



SWRFD-60L HARNESS



Antenna Adapter



SWC CABLE

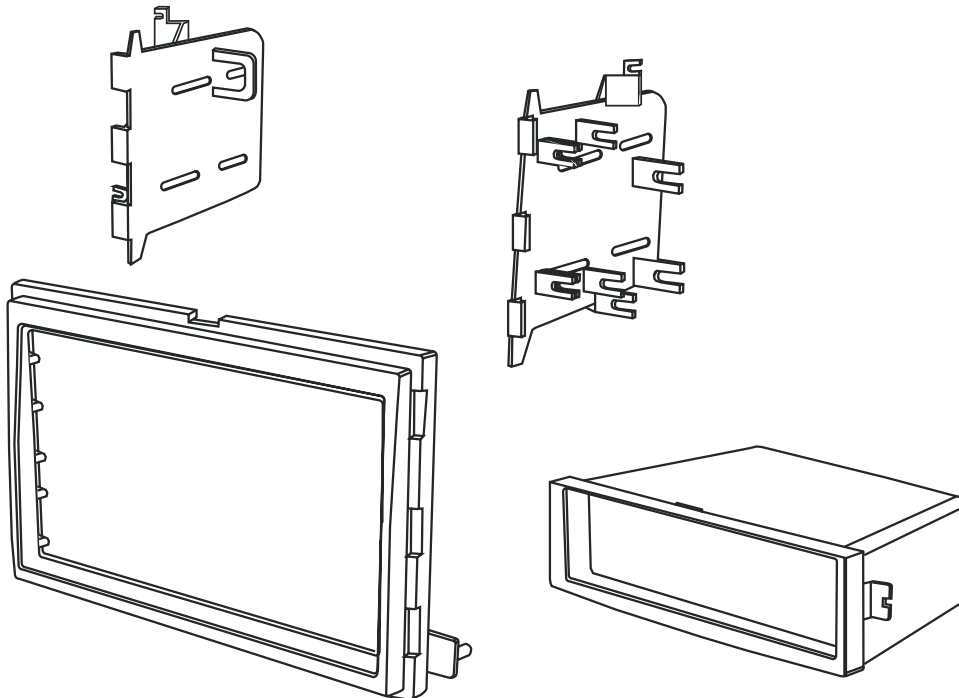



INSTALLATION DIAGRAM:

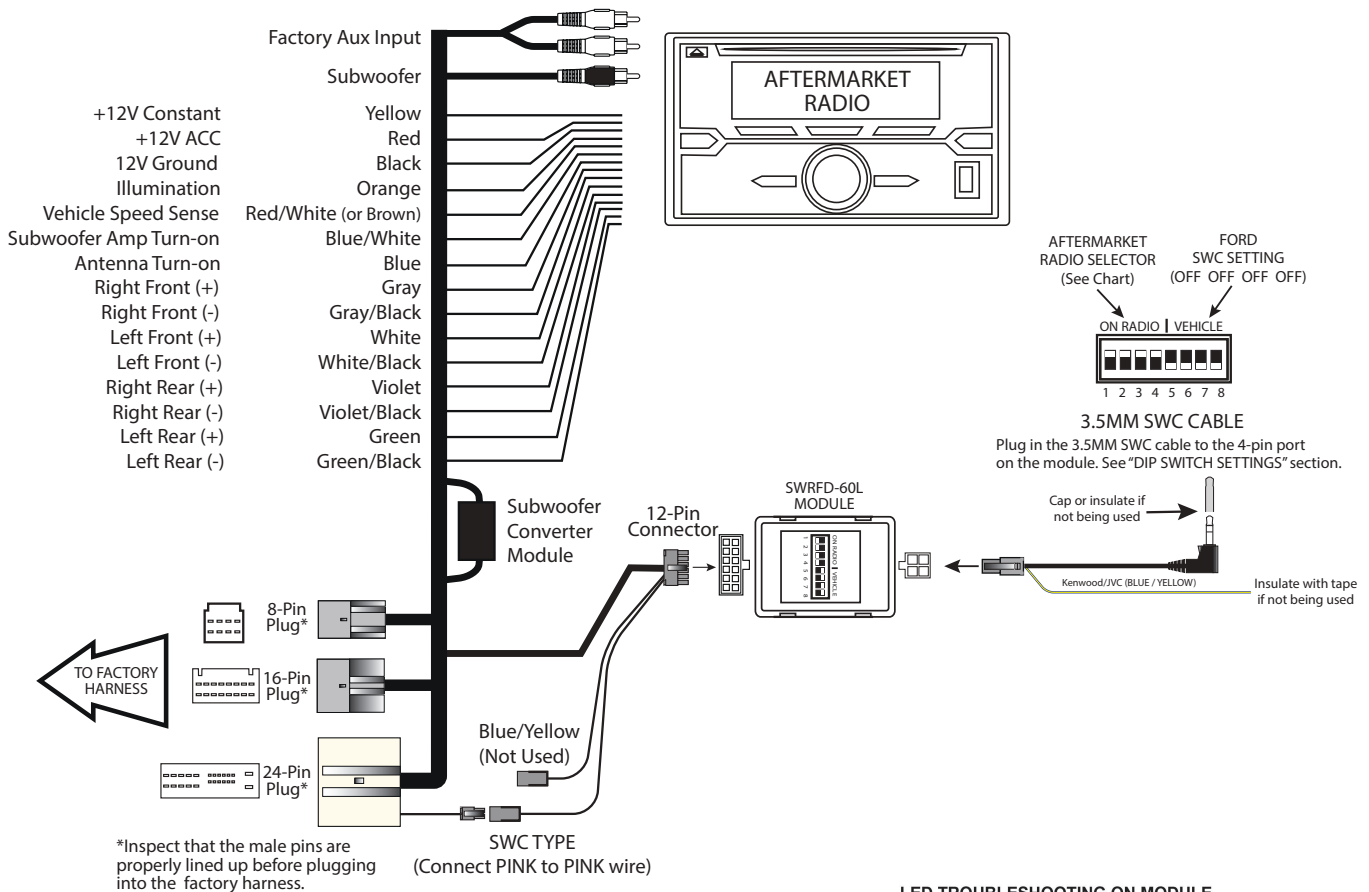

LED LIGHT	LED MODULE FEEDBACK	
BLUE LED OFF	NO POWER	CHECK VOLTAGE
RED LED FLASHES	WHEN PRESSING SWC BUTTONS	

NOTES:

1. Only supports analog Steering Wheel Control type.
2. Use part number SWRFD-60 for CAN Bus Steering Wheel Control.
3. Output signal stated above may not cover all Year/Model.
4. Does not retain SYNC.
5. Not compatible with factory-installed Sony systems and THX systems with amplifier.





ANALOG CONNECTION:

HOW TO DETERMINE IF THE VEHICLE HAS ANALOG SWC:

Analog Steering Wheel Control (SWC) signal vehicles will have wires populated and line up to the PINK and BLACK wire on the 24-Pin Crux connector.

If one wire is missing then you will need to use Crux part number SWRFD-60.

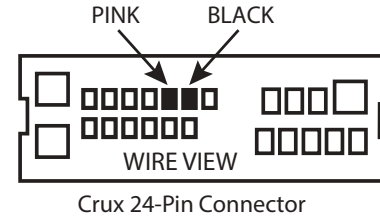

DIP SWITCH SETTINGS:

AFTERMARKET RADIO DIP SWITCH SETTINGS:

RADIO BRAND:	DIP:	1	2	3	4
Atoto, Dual, Farenheit, Jensen, Pioneer		OFF	OFF	ON	ON
Power Acoustik, Soundstream		OFF	OFF	ON	ON
Blaupunkt, Most off-brand Radios		OFF	OFF	ON	ON
Alpine		OFF	OFF	OFF	OFF
Clarion		OFF	ON	ON	OFF
Kenwood		OFF	ON	ON	ON
JVC		OFF	ON	OFF	ON
Boss, Old Sony		OFF	ON	OFF	OFF
New Sony		OFF	OFF	ON	OFF

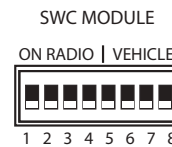

NOTE: For Atoto, Blaupunkt, Dual, Farenheit, Power Acoustik, Soundstream, and most off-brand radios, check the aftermarket radio's manual to see if the SWC buttons need to be programmed.

FORD STEERING WHEEL CONTROL DIP SWITCH SETTING:

DIP:	5	6	7	8
Ford	OFF	OFF	OFF	OFF

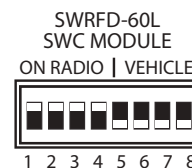

3.5MM SWC CABLE

Plug in the 3.5MM to 4-Pin SWC cable to the SWC module.

NOTE: Insulate the Blue/Yellow and Green wires if not being used.

For aftermarket radios that have wires for SWC connections, cut off the 3.5mm plug on the Crux SWC Cable (option B) and connect the SWC wires as follows:

Note that there are some radios that only have SWC1 and SWC2, in this case "shield" does not need to be connected.

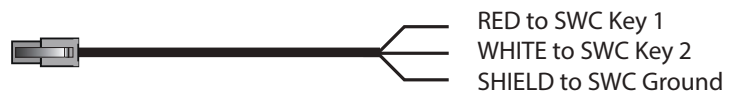



VEHICLE APPLICATIONS:

FORD

2007 – 2010 Edge
 2008 – 2012 Escape**
 2007 – 2010 Expedition
 2006 – 2010 Explorer
 2007 – 2010 Explorer Sport Trac
 2009 – 2008 F-150
 2009 – 2012 F-150*
 2008 – 2012 F-Series Super Duty
 2005 – 2007 Five Hundred
 2007 – 2008 Focus
 2004 – 2007 Freestar
 2005 – 2007 Freestyle
 2006 – 2009 Fusion
 2005 – 2009 Mustang
 2008 – 2009 Taurus

LINCOLN

2006 – 2008 Mark LT
 2007 – 2010 MKX (Nav only)
 2007 – 2011 Navigator (Nav only)

MERCURY

2008 – 2010 Mariner**
 2006 – 2009 Milan
 2005 – 2007 Montego
 2004 – 2007 Monterey
 2006 – 2010 Mountaineer
 2008 – 2009 Sable

MAZDA

2009 – 2011 Tribute**

*Not compatible on vehicles equipped with acclimated radio/climate control panel.

**Compatible with vehicles equipped with factory navigation radio only.

Compatible Ford SWC Types:



Type 1
4-Button



Type 2
4-Button



Type 3
5-Button



Type 4
6-Button





Radio Replacement Interface with Steering Wheel Control Retention with Dash Kit for FORD, LINCOLN & MERCURY

SINGLE ISO MOUNT INSTALLATION INSTRUCTIONS

1. Insert ISO brackets to rear of kit as shown in Figure A
2. Insert pocket into lower section of kit from rear & lock into slots of mounting brackets.
3. Insert ISO mountable radio between ISO mount brackets and loosely attach to sides of radio using screws provided with radio when possible or screws supplied with kit.
4. Slide radio forward or backward for desired look and tighten screws.
5. Attach a rear support bracket to the rear of the new radio and adjust as necessary to support the weight of the radio (Optional)

Fig. A

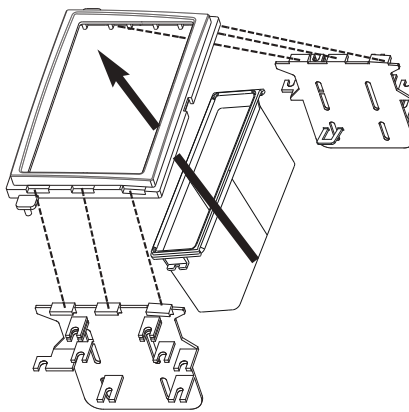

DOUBLE DIN MOUNT INSTALLATION INSTRUCTIONS

1. Attach left and right mounting brackets to the kit as shown in the figure below.
2. Insert ISO mountable radio between ISO mount brackets and loosely attach to sides of radio using screws provided with radio when possible or screws supplied with kit.
3. Slide radio forward or backward for desired look and tighten screws.
4. Support the rear of the radio component with back strap (optional). Remove shaded tabs on left and right sides of the brackets (Right side not shown)

Fig. B

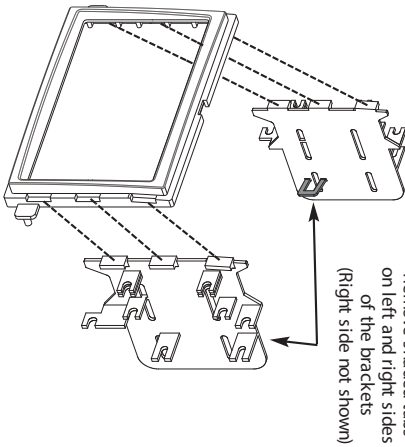

BRACKET PREPARATION

For all vehicles listed below, remove the shaded mounting tabs on both left and right brackets.

Fig. A

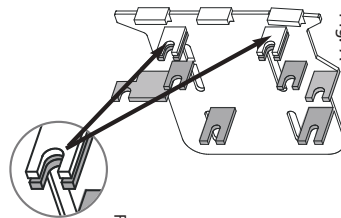

FOR FIGURE A REMOVE SHADED MOUNTING TABS ON BOTH LEFT AND RIGHT BRACKETS FOR:
 FORD 500
 2004-08 FORD F-150
 FORD FREESTYLE
 FORD MUSTANG
 FORD TRANSIT CONNECT
 TAURUS/TAURUS X
 MERCURY MONTEGO
 LINCOLN MARK LT

Fig. B

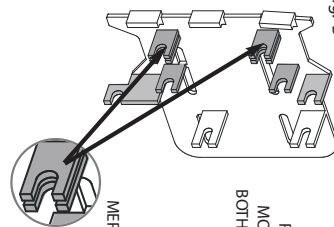

FOR FIGURE B REMOVE SHADED MOUNTING TABS ON BOTH LEFT AND RIGHT BRACKETS FOR:
 FORD FREESTAR
 FORD FOCUS
 2005-08 FORD SUPER DUTY
 MERCURY MONTEREY

Fig. C

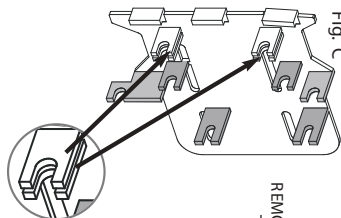

FOR FIGURE C REMOVE SHADED MOUNTING TABS ON BOTH LEFT AND RIGHT BRACKETS FOR:
 FORD EXPLORER
 FORD EXPLORER EXPLORER SPORT TRAC
 FORD FUSION
 LINCOLN ZEPHYR
 MERCURY MILAN
 MERCURY MOUNTAINEER

Fig. D

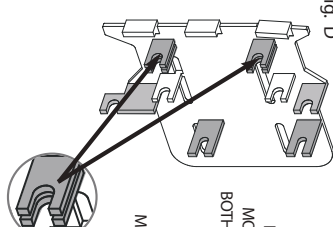

FOR FIGURE D REMOVE SHADED MOUNTING TABS ON BOTH LEFT AND RIGHT BRACKETS FOR:
 FORD ESCAPE
 MAZDA TRIBUTE
 MERCURY MARINER

Fig. E

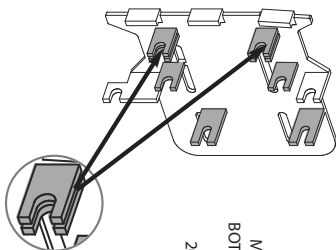

FOR FIGURE E REMOVE SHADED MOUNTING TABS ON BOTH LEFT AND RIGHT BRACKETS FOR:
 2009-14 FORD F-150

Fig. F

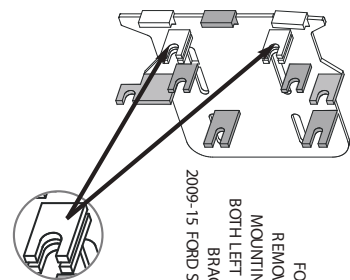

FOR FIGURE F REMOVE SHADED MOUNTING TABS ON BOTH LEFT AND RIGHT BRACKETS FOR:
 2009-15 FORD SUPER DUTY





2005-07 FORD FREESTYLE

DASH DISASSEMBLY INSTRUCTIONS

NOTE: See illustration A on page 2 for bracket preparation

1. Open the storage compartment located above the Radio/Vent trim bezel.
2. Starting from the top edge and working your way down the sides toward the bottom, carefully pry the Radio/Climate control trim bezel forward, disconnect all harnesses from the rear of the trim bezel and remove bezel.
3. Remove the (4) 9/32 screws securing the radio to the sub-dash. Carefully pull radio forward, disconnect all harnesses and antenna lead and remove radio.

2005-09 FORD MUSTANG

DASH DISASSEMBLY INSTRUCTIONS

NOTE: See illustration A on page 2 for bracket preparation

1. Carefully remove the trim from around the gearshift.
2. Remove the (2) Phillips screws located under the center console lid.
3. Lift up on the emergency brake and carefully remove the center console.
4. Carefully unclip and remove the trim panels at the left and right side of the radio.
5. Remove the (4) 9/32 screws securing the radio trim bezel to the sub-dash, carefully pull trim bezel forward, disconnect all attached harnesses and remove trim bezel.
6. Remove the (4) 9/32 screws securing the radio to the sub-dash, carefully pull radio forward and disconnect all harnesses and antenna lead and remove radio.

2005-08 FORD Super Duty

DASH DISASSEMBLY INSTRUCTIONS

NOTE: See illustration B on page 2 for bracket preparation

1. Engage the parking brake.
2. For Automatic Transmission Vehicles only, insert key into the ignition and turn to the ON position and depress the brake pedal, (DO NOT START THE VEHICLE!) then place the shift lever into the lowest position.
3. Lower the steering column all the way down.
4. Starting at the top edge of the dash trim bezel, carefully unclip and pull forward the dash trim bezel to access all the wire harness connectors attached to the features on the rear of the trim bezel.
5. Carefully disconnect all the connectors on the back side of the dash trim bezel and remove bezel.
6. Remove the (4) 9/32 screws securing the radio to the sub-dash.
7. Carefully pull radio forward, disconnect the wire harnesses and antenna lead from the rear of the radio and remove radio.

2005-07 FORD FOCUS

DASH DISASSEMBLY INSTRUCTIONS

NOTE: See illustration B on page 2 for bracket preparation

1. Carefully pry forward and unclip Radio/Climate control trim bezel and disconnect the 12 Volt Receptacle plug from the rear of the bezel.
2. Lay the trim bezel assembly out of the way (Disconnecting the climate control cables or harnesses is not necessary).
3. Remove the (4) 9/32 screws securing the radio to the sub-dash.
4. Carefully pull Factory radio forward, disconnect the wire harness and antenna lead from the rear of the radio and remove radio.

2004-07 FORD FREESTAR

2004-07 MERCURY MONTEREY

DASH DISASSEMBLY INSTRUCTIONS

NOTE: See illustration B on page 2 for bracket preparation

1. Carefully unclip and remove the radio/climate control trim bezel from around the factory radio.
2. Disconnect the harnesses from the rear of the radio/climate control bezel and remove bezel.
3. Remove the (4) 9/32 screws securing the factory radio to the sub-dash.
4. Carefully pull radio forward, disconnect the wire harness and antenna lead from the factory radio and remove radio.

2006-10 FORD EXPLORER

2006-10 MERCURY MOUNTAINEER (NAV ONLY)

2007-10 EXPLORER SPORT TRAC

DASH DISASSEMBLY INSTRUCTIONS

NOTE: See illustration C on page 2 for bracket preparation

1. Open the center console and remove the (2) 9/32 screws from the center console shifter trim.
2. Carefully lift up on the center console shifter trim and disconnect the 12 volt receptacle harness and remove trim.
3. Carefully pry outward on the radio trim bezel to release the panel clips, then lift the lower sides upward and slightly outward to clear the shift lever.
4. Disconnect all harnesses from the radio trim bezel and remove bezel.
5. Remove the (4) 9/32 screws securing the radio to the sub-dash.
6. Pull radio forward, disconnect all harnesses and antenna lead and remove radio.

2006-09 FORD FLUION

2006-08 LINCOLN ZEPHYR

2006-09 MERCURY MILAN

DASH DISASSEMBLY INSTRUCTIONS

NOTE: See illustration C on page 2 for bracket preparation

1. Starting from the bottom, carefully pry the factory radio trim bezel from around the radio forward, disconnect all harnesses attached to the rear of the trim bezel and remove bezel.
2. Remove the (4) 9/32 screws securing the radio to the sub-dash.
3. Carefully pull radio forward, disconnect all harnesses and antenna lead and remove radio.

2008-11 FORD ESCAPE

2008-11 MAZDA TRIBUTE/MERCURY MARINER

DASH DISASSEMBLY INSTRUCTIONS

NOTE: See illustration D on page 2 for bracket preparation

1. Carefully pry the Vent assembly above the radio forward.
2. Remove the (2) 9/32 screws securing the top of the radio/Climate control assembly to the sub-dash.
3. Carefully pry the LOWER 12 Volt/ USB/ Auxiliary plug panel forward, disconnect all attached harnesses and remove panel.
4. Remove the (2) 9/32 screws securing the lower edge of the Radio/Climate control assembly.
5. Set the parking brake





2005-07 FORD FREESTYLE

DASH DISASSEMBLY INSTRUCTIONS

NOTE: See illustration A on page 2 for bracket preparation

1. Open the storage compartment located above the Radio/Vent trim bezel.
2. Starting from the top edge and working your way down the sides toward the bottom, carefully pry the Radio/Climate control trim bezel forward, disconnect all harnesses from the rear of the trim bezel and remove bezel.
3. Remove the (4) 9/32 screws securing the radio to the sub-dash. Carefully pull radio forward, disconnect all harnesses and antenna lead and remove radio.

2005-09 FORD MUSTANG

DASH DISASSEMBLY INSTRUCTIONS

NOTE: See illustration A on page 2 for bracket preparation

1. Carefully remove the trim from around the gearshift.
2. Remove the (2) Phillips screws located under the center console lid.
3. Lift up on the emergency brake and carefully remove the center console.
4. Carefully unclip and remove the trim panels at the left and right side of the radio.
5. Remove the (4) 9/32 screws securing the radio trim bezel to the sub-dash, carefully pull trim bezel forward, disconnect all attached harnesses and remove trim bezel.
6. Remove the (4) 9/32 screws securing the radio to the sub-dash, carefully pull radio forward and disconnect all harnesses and antenna lead and remove radio.

2005-08 FORD Super Duty

DASH DISASSEMBLY INSTRUCTIONS

NOTE: See illustration B on page 2 for bracket preparation

1. Engage the parking brake.
2. For Automatic Transmission Vehicles only, insert key into the ignition and turn to the ON position and depress the brake pedal, (DO NOT START THE VEHICLE!) then place the shift lever into the lowest position.
3. Lower the steering column all the way down.
4. Starting at the top edge of the dash trim bezel, carefully unclip and pull forward the dash trim bezel to access all the wire harness connectors attached to the features on the rear of the trim bezel.
5. Carefully disconnect all the connectors on the back side of the dash trim bezel and remove bezel.
6. Remove the (4) 9/32 screws securing the radio to the sub-dash.
7. Carefully pull radio forward, disconnect the wire harnesses and antenna lead from the rear of the radio and remove radio.

2005-07 FORD FOCUS

DASH DISASSEMBLY INSTRUCTIONS

NOTE: See illustration B on page 2 for bracket preparation

1. Carefully pry forward and unclip Radio/Climate control trim bezel and disconnect the 12 Volt Receptacle plug from the rear of the bezel.
2. Lay the trim bezel assembly out of the way (Disconnecting the climate control cables or harnesses is not necessary).
3. Remove the (4) 9/32 screws securing the radio to the sub-dash.
4. Carefully pull Factory radio forward, disconnect the wire harness and antenna lead from the rear of the radio and remove radio.

2004-07 FORD FREESTAR

2004-07 MERCURY MONTEREY

DASH DISASSEMBLY INSTRUCTIONS

NOTE: See illustration B on page 2 for bracket preparation

1. Carefully unclip and remove the radio/climate control trim bezel from around the factory radio.
2. Disconnect the harnesses from the rear of the radio/climate control bezel and remove bezel.
3. Remove the (4) 9/32 screws securing the factory radio to the sub-dash.
4. Carefully pull radio forward, disconnect the wire harness and antenna lead from the factory radio and remove radio.

2006-10 FORD EXPLORER

2006-10 MERCURY MOUNTAINEER (NAV ONLY)

2007-10 EXPLORER SPORT TRAC

DASH DISASSEMBLY INSTRUCTIONS

NOTE: See illustration C on page 2 for bracket preparation

1. Open the center console and remove the (2) 9/32 screws from the center console shifter trim.
2. Carefully lift up on the center console shifter trim and disconnect the 12 volt receptacle harness and remove trim.
3. Carefully pry outward on the radio trim bezel to release the panel clips, then lift the lower sides upward and slightly outward to clear the shift lever.
4. Disconnect all harnesses from the radio trim bezel and remove bezel.
5. Remove the (4) 9/32 screws securing the radio to the sub-dash.
6. Pull radio forward, disconnect all harnesses and antenna lead and remove radio.

2006-09 FORD FLUION

2006-08 LINCOLN ZEPHYR

2006-09 MERCURY MILAN

DASH DISASSEMBLY INSTRUCTIONS

NOTE: See illustration C on page 2 for bracket preparation

1. Starting from the bottom, carefully pry the factory radio trim bezel from around the radio forward, disconnect all harnesses attached to the rear of the trim bezel and remove bezel.
2. Remove the (4) 9/32 screws securing the radio to the sub-dash.
3. Carefully pull radio forward, disconnect all harnesses and antenna lead and remove radio.

2008-11 FORD ESCAPE

2008-11 MAZDA TRIBUTE/MERCURY MARINER

DASH DISASSEMBLY INSTRUCTIONS

NOTE: See illustration D on page 2 for bracket preparation

1. Carefully pry the Vent assembly above the radio forward.
2. Remove the (2) 9/32 screws securing the top of the radio/Climate control assembly to the sub-dash.
3. Carefully pry the LOWER 12 Volt/ USB/ Auxiliary plug panel forward, disconnect all attached harnesses and remove panel.
4. Remove the (2) 9/32 screws securing the lower edge of the Radio/Climate control assembly.
5. Set the parking brake

