

PRODUCT FEATURES:

- Interface includes Audio / Video Input to connect an extra A/V source.
- OEM style Spare Tire mount reverse camera included.
- Camera has moving parking guide lines to show path direction while backing up.
- Activates MYGIG Screen for enabling Video features.
- Supports vehicles with manual transmission. See note below.
- Plug and Play connections for ease of use.

NOTE: Does not supply +12V Reverse Trigger on vehicles with manual transmission. Camera power must be tapped from the +12V reverse light wire instead.

PARTS INCLUDED:



CH-75WM MODULE



CH-75WM HARNESS



CCH-01M SPARE TIRE MOUNT CAMERA with MOVING LINES



INSTALLATION DIAGRAM:

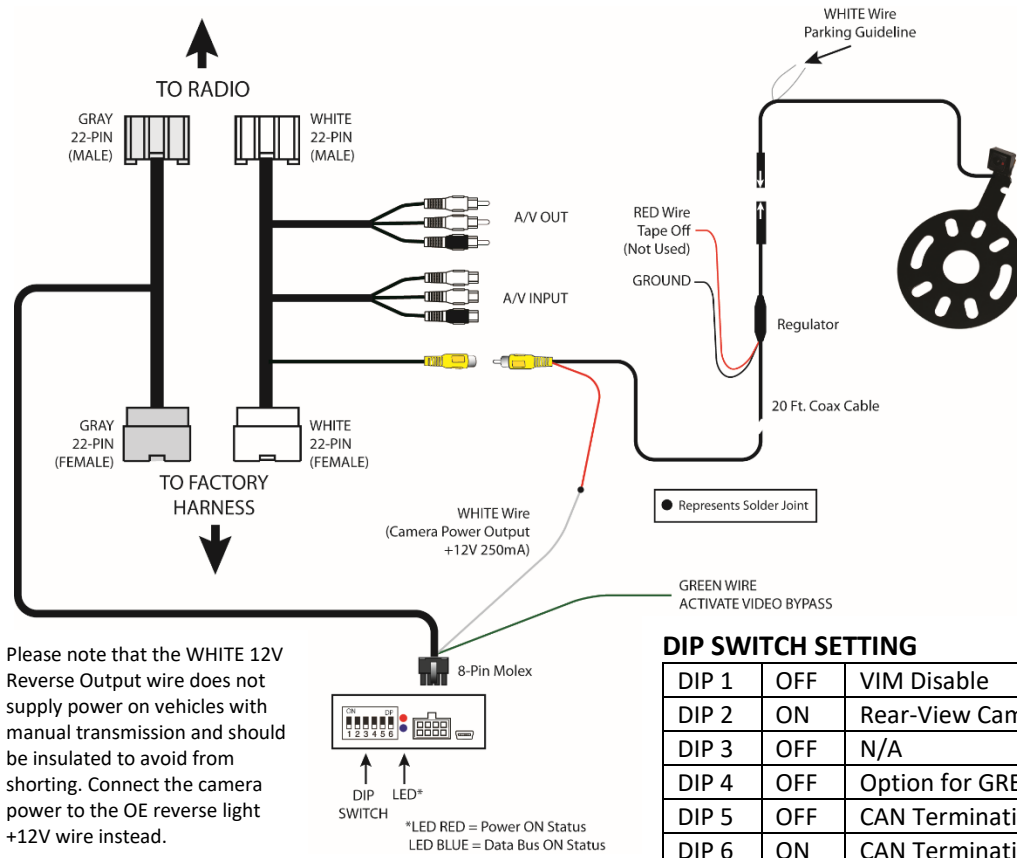

INSTALLATION:

INSTALLING THE CAMERA AND INTERFACE

1. Remove the outside mounted spare tire.
2. Mount the camera's metal bracket onto the spare tire bolts and secure with the star washers.
3. Route the cable towards the radio and make the power and video connections.
4. Remove the factory radio to gain access to the factory connectors.
5. Plug in the T-harness with WHITE and GRAY connectors. (See Wiring Diagram above)
6. Connect the 8-pin Molex connector from the T-harness with GRAY connectors to the CAN Interface.
7. Use the WHITE 12V Reverse Output wire to power the camera (see Wiring Diagram above). **DO NOT connect the red power wire, near the camera, to the reverse light and insulate this red wire to avoid from shorting.** If the vehicle has a manual transmission, the camera power must be tapped to the +12V reverse light wire instead. In this case the WHITE 12V Reverse Output wire is not used and should be insulated to avoid from shorting.
8. Plug in the YELLOW MALE RCA from the camera cable to the YELLOW FEMALE RCA of the T-Harness with WHITE connectors.
9. Connect GREEN wire to +12V for a non permanent Video in Motion feature.
10. Set the proper DIP Switch settings on the CAN Interface. (See Chart above)
11. Cut the thin white wire on the camera cable to enable the parking guide lines.
12. Test the camera before re-installing the radio.



PARKING LINES:

The parking lines are there to assist you while reversing. To activate the parking lines simply cut/disconnect the WHITE loop wire located near the 4 pin camera connector.

What the Lines mean:

- Green Line: CLEAR
- Yellow Line: GETTING CLOSE
- Red Line: WARNING - VERY CLOSE
- White Line: SHOWS THE PATH DIRECTION



SWITCHING SOURCES:

VES will be your source for the AV Input.



To access the VES button, press the RADIO/MEDIA button on the left side of the radio. The VES button is only active after the interface is properly installed.

VEHICLE APPLICATIONS:

JEEP

2007 – 2017 WRANGLER

COMPATIBLE RADIO:

MyGig Radio

