

## PRODUCT FEATURES:

- Retains factory features in select Audi vehicles while functioning with an aftermarket radio.
- Supports amplified and non-amplified systems.
- EIA color coded wiring for easy installation.

## NOTE:

Does not retain rotary type Steering Wheel Controls (SWC).



## PARTS INCLUDED:



SWRAD-55 MODULE

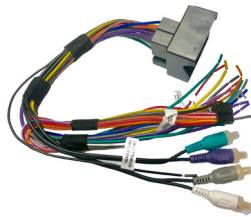

Quadlock Harness

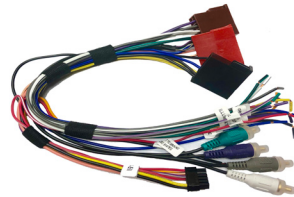

ISO Harness

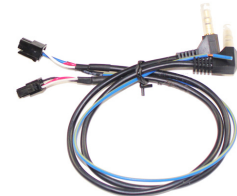

SWC Cables

## INSTALLATION DIAGRAM:

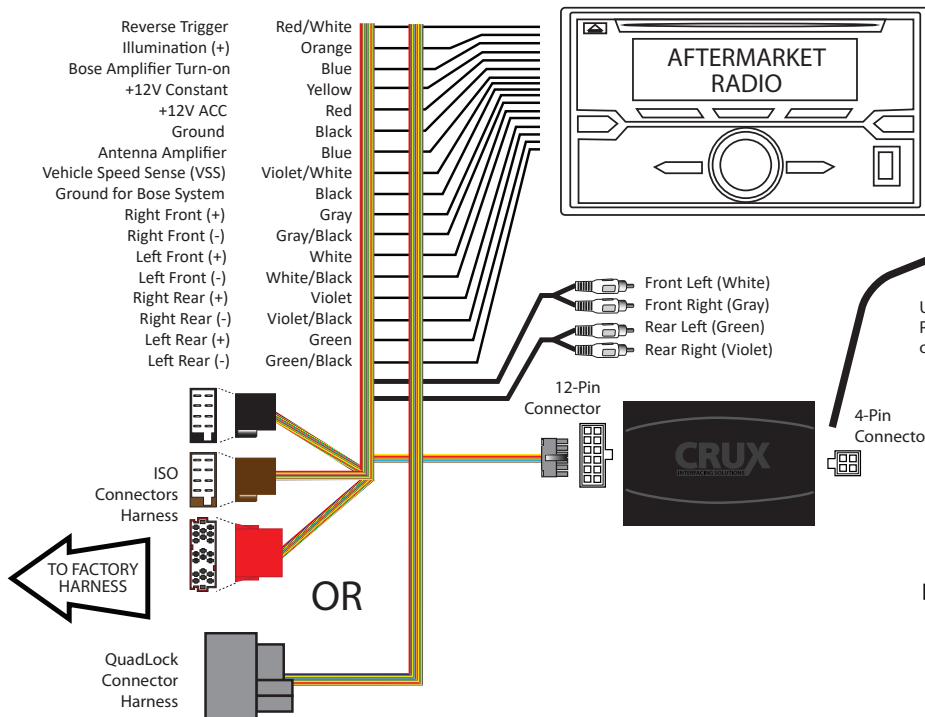

## TROUBLESHOOTING

LED LIGHT	LED MODULE FEEDBACK
Solid blue	CAN recognized
Flashing blue	CAN not recognized
Solid red	Module providing 12V ACC
Red off	12V ACC OFF

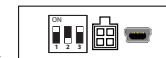

### 3.5MM SWC CABLES (Option A or B)

Use the proper 3.5MM to 4-Pin cable for your radio. Plug in the selected 3.5MM SWC cable to the 4-pin port on the module. See "DIP SWITCH SETTINGS" section.



Option B:

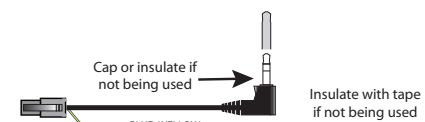

Option A:



**DIP SWITCH SETTINGS:**

**AFTERMARKET RADIO DIP SWITCH SETTINGS:**

RADIO BRAND:	DIP#:	1	2	3
Atoto, Dual, Fahrenheit, Jensen		OFF	ON	ON
Pioneer, Power Acoustik, Soundstream		OFF	ON	ON
Blaupunkt, Most off-brand Radio		OFF	ON	ON
Alpine		OFF	OFF	OFF
Clarion		ON	ON	OFF
Kenwood		ON	ON	ON
JVC		ON	OFF	ON
Boss, Old Sony		ON	OFF	OFF
New Sony		OFF	ON	OFF

SWC MODULE  
DIP SWITCH



**NOTE:** For Atoto, Blaupunkt, Dual, Farenheit, Power Acoustik, Soundstream, and most off-brand radios, check the aftermarket radio's manual to see if the SWC buttons need to be programmed.

**3.5MM SWC CABLE**

Plug in the 3.5MM to 4-Pin SWC cable to the SWC module.

NOTE: Insulate the Blue/Yellow wire or 3.5mm plug if not being used.

For aftermarket radios that have wires for SWC connections, cut off the 3.5mm plug on the Crux SWC Cable (option B) and connect the SWC wires as follows:

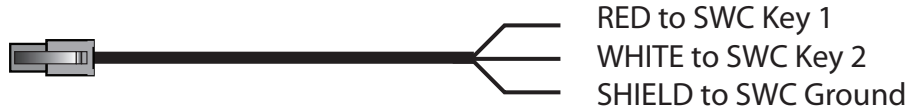

Note that there are some radios that only have SWC1 and SWC2, in this case "shield" does not need to be connected.

**USING THE RCA CONNECTORS:**

**For Bose System:**

Connect all 4 (front and rear) RCA connectors only. No speaker wire connections needed.

**For Non-Amplified Systems:**

Connect the 8 speaker wires. No RCA connection is needed.

**For Vehicles with Rear Factory Subwoofer amplifier:**

Connect the front channel speaker wires only. Then connect the rear RCA connectors.

**Note:** For Bose and Rear Factory Sub, connect the Blue wire.

**VEHICLE APPLICATIONS:**

**AUDI**

- 2002 - 2013 A3
- 2001 - 2007 A4
- 2008 - 2010 A5
- 2002 - 2011 A6
- 2003 - 2005 S4
- 2009 - 2010 Q5
- 2002 - 2014 TT

NOTE: Compatible with CONCERT, CHORUS and SYMPHONY radios.

