

PRODUCT FEATURES:

- Adds front and back up camera inputs plus an extra video input¹.
- Uses the steering wheel control buttons or radio buttons to toggle between the inputs.
- Picture-in-picture mode combining after-market rear-view and front camera picture(s) with factory parking sensor graphics.
- Interactive parking guide lines with calibration function.
- Simultaneous use of picture-in-picture factory parking sensor graphics and interactive lane lines
- Built-in on-screen display and setup.
- 2 trigger outputs (+12V max. 1A), separately adjustable switching events (CAN, ACC, camera, reverse gear)

NOTES:

1. Factory Audio Aux Input is required if video input will be used for AV sources.
2. The VRFVW-73C connects at the multimedia player located in the glove box.

PARTS INCLUDED:



VRFVW-73C Module

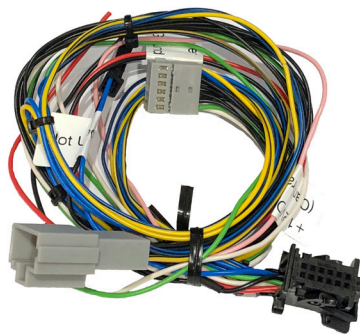

VRFVW-73C Harness



Video Harness



LVDS1 Cable (to vehicle)



LVDS 2 Cable (to radio)



INSTALLATION DIAGRAM:

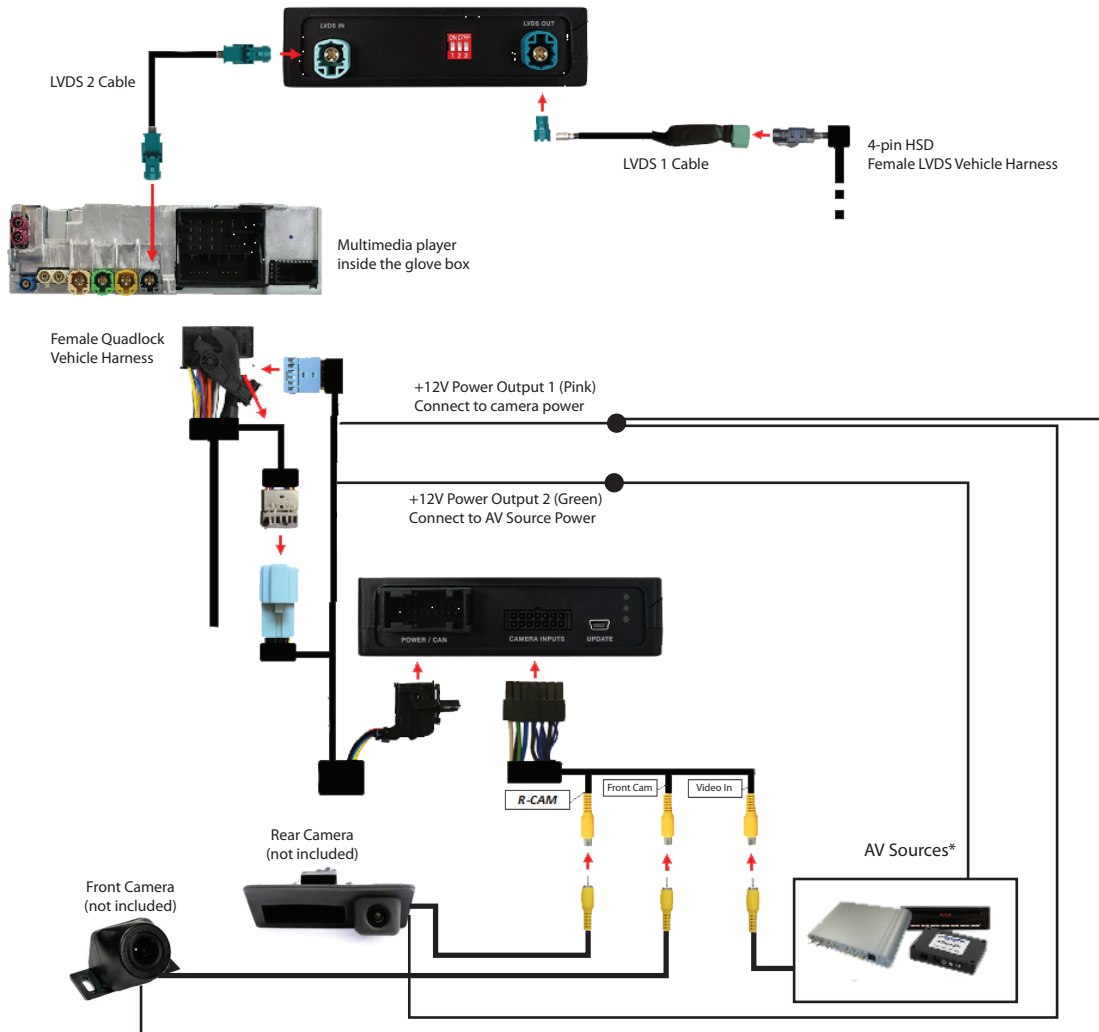

DIP SWITCH SETTINGS:

<u>VEHICLE</u>	<u>MONITOR SIZE</u>	<u>DIP 1</u>	<u>DIP 2</u>	<u>DIP 3</u>
VW Golf 7 / Sportsvan	6.5"	OFF	ON	OFF
VW Passat (B8)	6.5"	OFF	ON	ON
VW Passat (B8)	8"	ON	ON	OFF



INSTALLATION INSTRUCTIONS:

The sample installation instructions below is on a 2017 Audi A3. The installation of the VRFVW-73C on a Volkswagen is similar to the Audi. The unit is also plugged in at the media player which is in the glove compartment.



1. Installation is done behind the media player in the glove compartment.



2. Remove the dashboard side panel.



3. Remove the screw that holds the glove compartment.



4. Remove the other screws holding the glove compartment.



5. Pull down the glove compartment to show the media player.

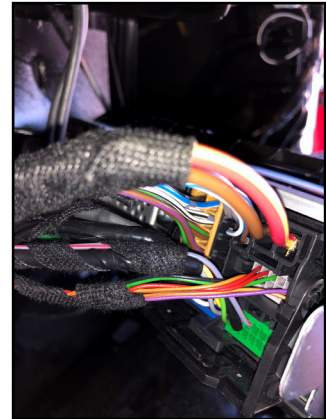

6. Remove the media player to gain access to the connectors on the back.





7. Unplug the Gray connector from the Quadlock connector.

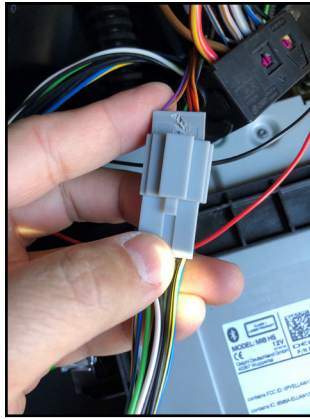

8. Plug in the Gray connector to the mate on the VRFVW-73C harness.

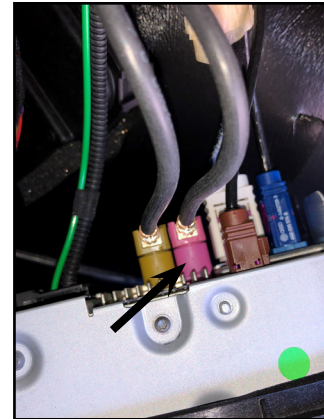

9. Locate the Pink LVDS connector and unplug this.

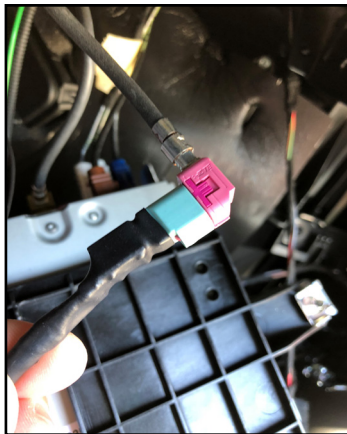

10. Plug the Pink LVDS cable to the LVDS 1 cable. Plug the other end of the LVDS 1 cable to the module LVDS OUT.



11. Plug one end of the LVDS 2 cable to the Pink LVDS port on the media player. Plug the other end of the LVDS 2 cable to the module LVDS IN.

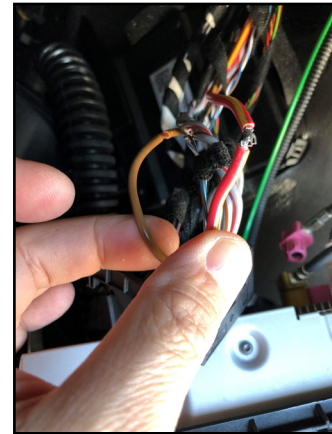

12. Tap the Red and Black wires of the VRFVW-73C harness to power & ground:
 Red to RED/YELLOW
 Black to BROWN



13. Tape the connections well to avoid short circuits.

14. Install the camera that will be used in the install. Run the camera cables towards the radio. The RCAs and camera power wires will plug into the VRFVW-73C harness.

+

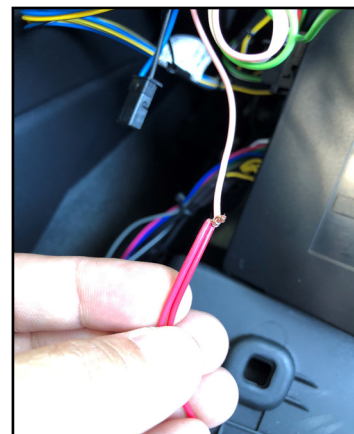

15. Connect the camera power wires to the PINK power output 1 wire.





16. Plug in connectors to the VRFVW-73C module.



17. Test the communication. Turn on the ignition and check if LEDs are on.

18. Test the cameras. Put gear in reverse and check for rear camera image on screen. Put gear in Drive and the front camera should turn on.

Once all the camera validation is complete, mount the VRFVW-73C module, reinstall the media player and glove compartment.

OSD SETTINGS:

OSD Menu

Use the following buttons to enter the VRFVW-73C OSD Menu:

VOLKSWAGEN



Use the PINK wire to power the Front and Side cameras. Set the OSD as follows:

Option 1 = CAM



Setting the Front Camera

(Use the PINK wire to power the Front camera)



OSD Menu	Menu Item	Setting	Description
Input	FVC	OFF	Front camera deactivated
		ON	Switches to front camera if parking process is enabled and reverse gear is released
Option 1	Park Logic	Intelligent	For vehicles with front-PDC. Enabled while parking process and up to 12 mph
		RGearOnly	Enabled while parking process (not suitable for front camera operation)
		RGearSpeed	Enabled while parking process and up to e.g. 7 mph (speed adjustable)
		RGearTime	Enabled while parking process and up to 20 seconds
Option 2	R/F Cam ON	XX	Speed setting for deactivating of the camera image
Option 2	PDC Graphic	OFF	OEM PDC display of the vehicle deactivated
		Horizontal	Vehicles with horizontal OEM PDC display
		Vertical	Vehicles with vertical OEM PDC display

Note: You can deactivate the camera image by a long press (2 sec.) of the rotation knob.



Setting the Side Cameras

(Use the PINK wire to power the Side cameras)



OSD Menu	Menu Item	Setting	Description
Option 2	R/F Cam Till	XX	Speed setting for deactivating of the camera image
Option 2	F/S Cam From	XX	Speed range setting for front- and side cameras (minimum)
Option 2	F/S Cam Till	XX	Speed range setting for front- and side cameras (maximum)
Option 2	Blinker Mode	Front Cam	Activation of the front camera image when the blinker is activated
Option 2	Cam Trigger	CAN	Rear gear and blinker signal detection over CAN Bus
		ANALOG	Rear gear and blinker signal detection over analogue +12V signals

Notes: You can deactivate the camera image by a long press (2 sec.) of the rotation knob. The camera activation via the blinker mode is only available for front camera or for the side view cameras. A parallel use of this function for all cameras is not possible.

Setting the Rear Aftermarket Camera

(Use the GREEN (12V Output) 2 wire to power the Front camera)

In the OSD Menu, set "Option 1" > menu item "Power Out 2" to "CAM"

If the aftermarket back up camera does not automatically switch on after putting the gear to reverse, you can use the analog setting instead. Connect the white wire from the VRFVW-73C harness to the analog reverse gear signal (+12V) wire. Set "Option 2" > "Cam Trigger" to Analog.





OSD Menu	Menu Item	Setting	Description
Input	RVC	OFF	Rear View camera deactivated
		ON	Switches to rear-view camera if reverse gear is engaged or PDC is activate
Option 1	Park Logic	Intelligent	For vehicles with PDC. Enabled while parking process and up to 12 mph (not suitable for front camera operation for vehicles without front PDC)
		RGearOnly	Enabled while parking process (not suitable for front camera operation)
		RGearSpeed	Enabled while parking process and up to e.g. 7 mph (speed adjustable)
		RGearTime	Enabled while parking process and up to 20 seconds
Option 1	RVC Lines	ON	Interactive lane lines activated
Option 2	R/F Cam Till	XX	Speed setting for deactivating of the camera image
Option 2	PDC Graphic	OFF	OEM PDC display of the vehicle deactivated
		Horizontal	Vehicles with horizontal OEM PDC display
		Vertical	Vehicles with vertical OEM PDC display
Option 2	Cam Trigger	CAN	Rear gear and blinker signal detection over CAN Bus
		Analog	Rear gear signal detection over analog +12V signals

Note: You can deactivate the camera image by a long press (2 sec.) of the rotation knob.

OSD Menu	Menu Item	Setting	Description
Input	RVC	OEM	If a factory rear-view camera is present. The interface turns off, if reverse gear is enabled and it displays factory rear-view camera
		Intelligent	For vehicles with front-PDC. Enabled while parking process and up to 12 mph.
Option 1	Park Logic	RGearSpeed	Enabled while parking process and up to e.g. 7 mph (speed adjustable)
		RGearTime	Enabled while parking process and up to 20 seconds
Option 2	R/F Cam Till	XX	Speed setting for deactivating of the camera image



AV Source

You can use AV2 or AV3 to plug in an external video source. Please note that the vehicle needs to have a factory AUX Input for audio to be heard through the factory sound system.

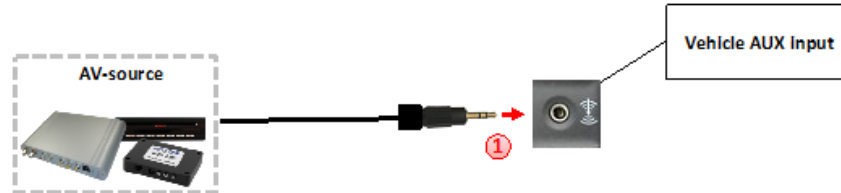

Use the PINK wire (12V OUTPUT 1) of the VRFVW-73C harness to power the external video source (max. 1A) of the AV source.



Go to the OSD menu and set "Option 1", menu item "Power Out 1" to "AVS" or "ACC".



OSD Menu	Menu Item	Setting	Description
Input	Right VC/AV	OFF	No camera / AV source connected
		RCxx	AV source connected to the AV-2 input
	Left VC/AV	OFF	No camera / AV source connected
		RCxx	AV source connected to the AV-3 input

Note: Select "RC01" if AV source control function is via touchscreen and control knob is not used.

In the vehicle's Media menu, activate AUX Input (only necessary for AV source operation) to get sound through the vehicle's audio system. Press the "MEDIA" button for 3 to 5 seconds to go to AV mode.

A short press of the "MEDIA" button (or additionally on touchscreen the swipe gesture) will toggle through the video sources. Each short press will toggle to the next enabled input. If all inputs are enabled the order is:

Rear CAM > Front CAM > Right Cam/AV > Left Cam/AV > ... Inputs which are not enabled are skipped.

To exit AV mode, press the "MEDIA" button for 3 to 5 seconds or by a short press of "RADIO/NAV/TEL/PHONE/CAR" button.



Configurable Trigger Outputs

You can configure the both +12V trigger outputs separately in the OSD menu. The PINK wire (12V OUTPUT 1) is Power Out 1 and the GREEN wire (12V OUTPUT 2) is Power Out 2.



OSD Menu	Menu Item	Setting	Description
Option	Power Out 1 (PINK)	CAM	+12V when the interface is on (red LED on)
		ACC	+12V when ignition is on
		Cam	+12V when camera input is activated (manually or automatically)
	Power Out 2 (GREEN)	RGear	+12V when reverse gear is engaged
		AVS	+12V when camera / video input was manually activated
		OFF	Trigger output deactivated

Tip: We recommend for all camera to use power out setting “Cam” and for AV source the power out setting of “AVS” or “ACC”.

Interactive Lane Lines

The VRFVW-73C includes an Interactive Lane Lines function that is added to the aftermarket rear view camera. Use the OSD menu to activate this feature.

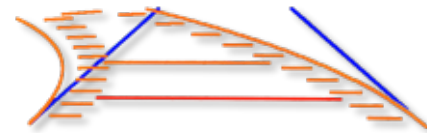

OSD Menu	Menu Item	Setting	Description
Option	RVC Lines	OFF	Interactive lane lines deactivated
		ON	Interactive lane lines activated
	Car Type	PASSAT / GOLF 7	Vehicle Type Selection



Interactive Lane Lines Settings

The height and width of the interactive lane lines can be set in the OSD menu. For this setting you must first activate the rear view camera level and push the “MENU”/ “HOME”(Porsche) button for 2 seconds to activate the settings menu. With the rotation knob you can select the menu point “Line Height” to change the height of the interactive lane lines and with menu point “Line Width” the width of the lines. Click “Exit” to leave the settings menu.



Picture Settings

The camera picture can be set in the OSD menu. For this setting you must first activate the camera level and push the “MENU”/”HOME” (Porsche) button for 2 seconds to activate the settings menu. With the rotation knob you can select and change the “Brightness”, “Contrast”, “Saturation”, Hue” and “Sharpness”. Click “Exit” to leave the settings menu.



Note: The picture settings will be retained for every camera input separately.

OSD Settings

You can change the basic configurations of the interface in the OSD (on screen display).



OSD Menu	Menu Item	Setting	Description
OSD	POS. X	0-xxx	Horizontal position of the OSD
	POS. Y	0-xxx	Vertical position of the OSD
	Size	Small	Small OSD menu window
		Large	Large OSD menu windows
	Osd TimeOut	2-20	Time setting for automatic OSD shutoff
Info	Version	X.XX.XX	Displays the current SW-version
Option 1	Factory Reset		Reset to factory default settings



VEHICLE APPLICATIONS:

Volkswagen 2015 - Up 2015 - Up	Golf 7 Passat (B8)	MIB/MIB2 - Discovery Pro 8" and Composition Media 6.5" monitor
---	-----------------------	---



2017 Golf



2017 Passat

