

PRODUCT FEATURES:

- Retains factory features in select Chrysler, Dodge and Jeep vehicles while functioning with an aftermarket radio.
- Retains Steering Wheel Controls via built-in, pre-programmed interface.
- Supports amplified and non-amplified systems.
- Provides reverse trigger for rear view camera.
- EIA color coded wiring for easy installation.

NOTES:

1. The Front and Rear fading are NON-Adjustable on amplified systems.
2. Also supports radio replacement in vehicles with 4.3" and 8.4" color screens.
3. Does not retain Uconnect.
4. If vehicle is not equipped with Steering Wheel Controls use part# SOOCR-26
5. If you require a dash kit with SWC interface use part# DKCR-59K

PARTS INCLUDED:



SWRCR-59 MODULE



1st Generation Harness



2nd Generation Harness



Audio Filter

INSTALLATION DIAGRAM:

The SWRCR-59 includes 2 harnesses for older and new model vehicles. See installation diagrams below for each harness.

1st Generation Harness

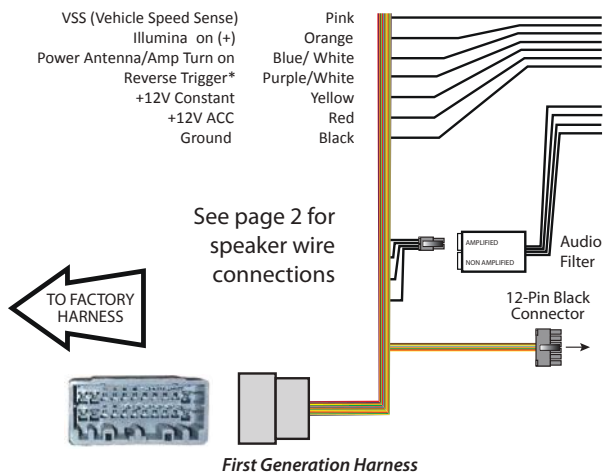

TROUBLESHOOTING

LED LIGHT	LED MODULE FEEDBACK
Solid blue	CAN recognized
Flashing blue	CAN not recognized
Solid red	Module providing 12V ACC
Red off	12V ACC OFF



3.5MM SWC CABLES (Option A or B)

Use the proper 3.5MM to 4-Pin cable for your radio. Plug in the selected 3.5MM SWC cable to the 4-pin port on the module. See "DIP SWITCH SETTINGS" section.

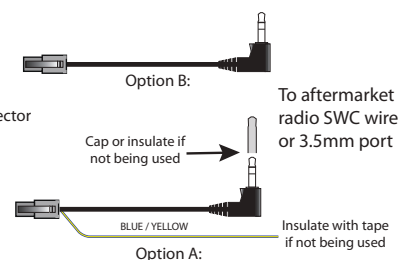

*Does not supply Reverse Trigger on Manual Transmissions. Reverse trigger wire from the aftermarket radio and/or camera power must be connected to factory reverse light wire instead.





2nd Generation Harness

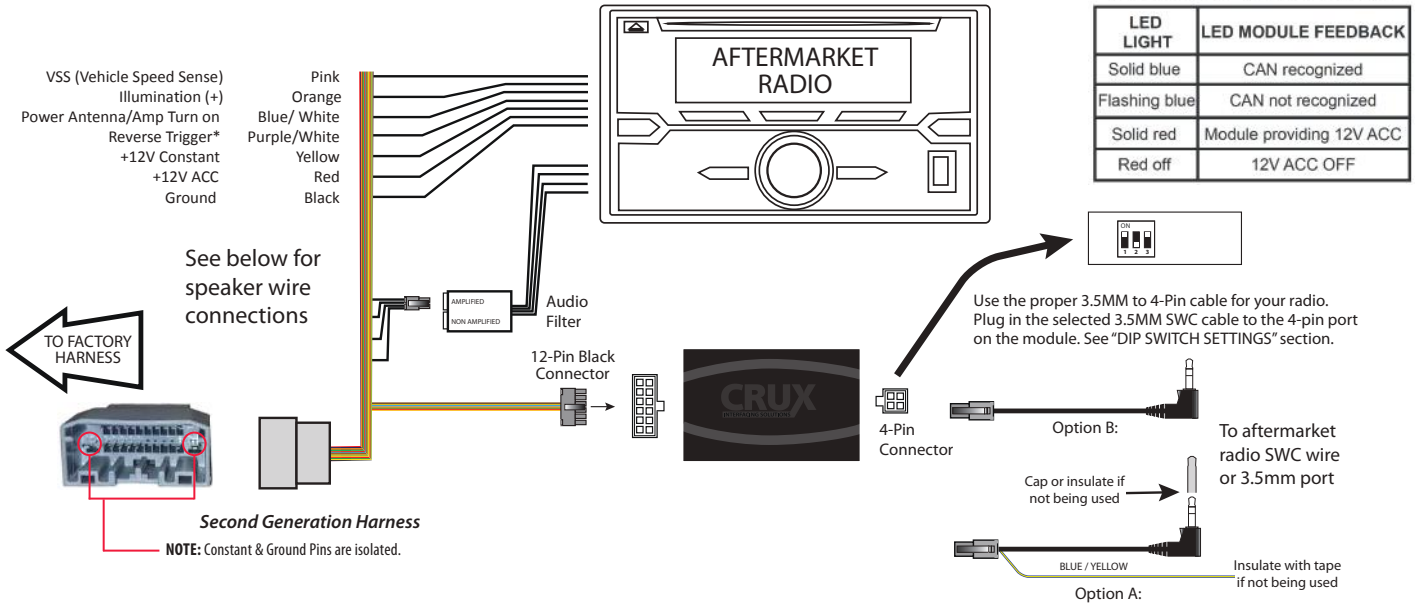

*Does not supply Reverse Trigger on Manual Transmissions. Reverse trigger wire from the aftermarket radio and/or camera power must be connected to factory reverse light wire instead.

Speaker wire connections:

Wire the audio filter using the connection chart below. Plug the 4 pin Molex plug found on the 1st or 2nd generation harness to the corresponding 4 pin Molex socket on the audio filter. (Amplified or Non-Amplified)

NON AMPLIFIED SYSTEMS		AMPLIFIED SYSTEMS	
Plug the 4-pin Molex connector to the NON-AMPLIFIED side of the inline filter.		Plug the 4-pin Molex connector to the AMPLIFIED side of the inline filter.	
Wire Connections:		Wire Connections:	
Aftermarket Radio	SWRCR-59 Harness	Aftermarket Radio	SWRCR-59 Harness
White	White	White	Green
White/Black	White/Black	White/Black	Green/Black
Gray	Gray	Gray	Purple
Gray/Black	Gray/Black	Gray/Black	Purple/Black
Green	Green	Green	Not Used
Green/Black	Green/Black	Green/Black	Not Used
Purple	Purple	Purple	Not Used
Purple/Black	Purple/Black	Purple/Black	Not Used

Amplified vehicle troubleshooting: Bluetooth may be inaudible when installing select aftermarket radios. Therefore hook the rear SWRCR-59 speakers to the aftermarket radio front speakers.



DIP SWITCH SETTINGS:

AFTERMARKET RADIO DIP SWITCH SETTINGS:

RADIO BRAND:	DIP#:	1	2	3
Atoto, Dual, Fahrenheit, Jensen, Nakamichi,		OFF	ON	ON
Pioneer, Power Acoustik, Soundstream		OFF	ON	ON
Blaupunkt, Most off-brand Radio		OFF	ON	ON
Alpine		OFF	OFF	OFF
Clarion, Stinger		ON	ON	OFF
Kenwood		ON	ON	ON
JVC		ON	OFF	ON
Boss, Old Sony		ON	OFF	OFF
New Sony (with CarPlay)		OFF	ON	OFF

SWC MODULE
DIP SWITCH



NOTE: For Atoto, Blaupunkt, Dual, Fahrenheit, Nakamichi, Power Acoustik, Soundstream, and most off-brand radios, check the aftermarket radio's manual to see if the SWC buttons need to be programmed.

4-PIN SWC CABLE

Use the proper 3.5MM to 4-Pin SWC cable for the aftermarket radio you are using.

OPTION A is used for ALPINE, CLARION, JVC, and KENWOOD units (Blue/Yellow wire is attached)
OPTION B is used for ATOTO, BLAUPUNKT, BOSS, DUAL, FARENHEIT, JENSEN, POWER ACOUSTIK,
PIONEER, SONY, SOUNDSTREAM and Most Off-Brand Radios.

NOTE: Cap or insulate the 3.5mm plug or Blue/Yellow wire if not being used.

For aftermarket radios that have wires for SWC connections, cut off the 3.5mm plug on the Crux SWC Cable (option B) and connect the SWC wires as follows:

Note that there are some radios that only have SWC1 and SWC2, in this case "shield" does not need to be connected.



VEHICLE APPLICATIONS:

CHRYSLER		DODGE		JEEP	
2011-2014	200	2007-2014	Avenger	2006-2010	Commander
2005-2010	300	2006-2012	Caliber	2007-2016	Compass
2007-2009	Aspen	2008-2014	Challenger	2005-2013	Grand Cherokee
2006-2010	PT Cruiser	2006-2010	Charger	2008-2012	Liberty
2007-2010	Sebring	2013	Charger	2007-2017	Patriot
2008-2016	Town & Country	2006-2011	Dakota	2007-2017	Wrangler
		2004-2013	Durango	2018	Wrangler (JK only)
		2009-2016	Grand Caravan		
		2009-2010	Journey	MITSUBISHI	
		2013	Journey	2006-2009	Raider
		2005-2008	Magnum		
		2007-2011	Nitro	VOLKSWAGEN	
		2006-2012	RAM	2009-2013	Routan

