

PRODUCT FEATURES:

- Retains factory features in select Toyota vehicles while functioning with an aftermarket radio.
- Pre-programmed to retain factory Steering Wheel Controls.
- Retains the factory JBL amplifier.
- Retains factory back-up camera and sensors.
- Retains factory bird's eye view feature (if equipped).
- Retains factory Auxiliary Audio Input.
- Includes factory USB retention adapter cable.
- Includes antenna adapter.

PARTS INCLUDED:



SWRTY-61P
SWC Module



TOY Box

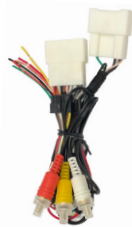

TY-61P Harness



Speaker
Harness



SWC Cable



USB Adapter



Antenna Adapter

INSTALLATION DIAGRAM:

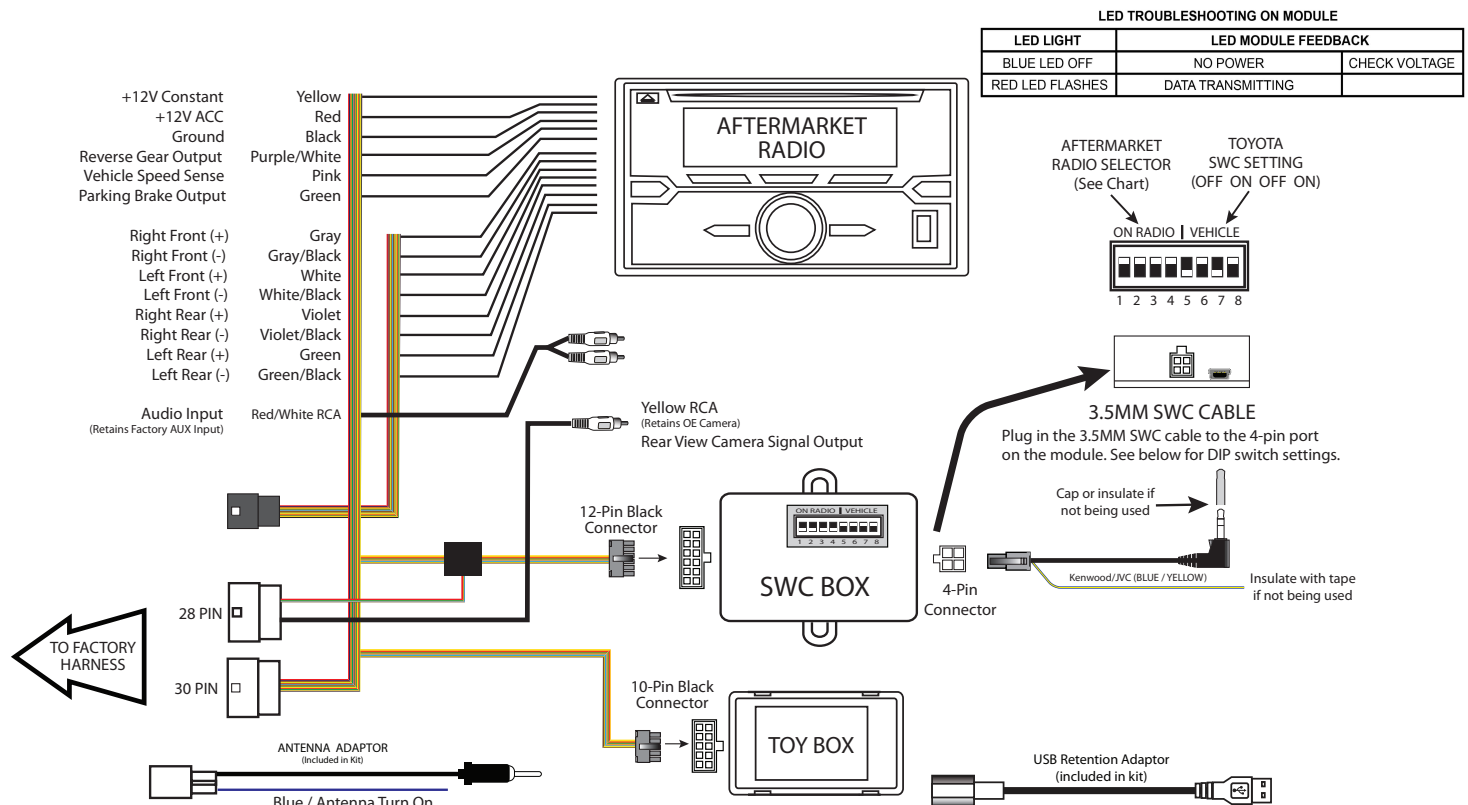

INSTALLATION INSTRUCTIONS:

1. Connect the SWRTY-61P T-harness to the aftermarket radio harness. Refer to the diagram on page 1 for wire color codes.



2. Remove the padded trim above the glove compartment.



3. Carefully pull out the trim under the radio.



4. Remove the small trim next to the shifter.



5. Remove the AC control panel below the radio.



6. Unplug the connector behind the AC control panel.

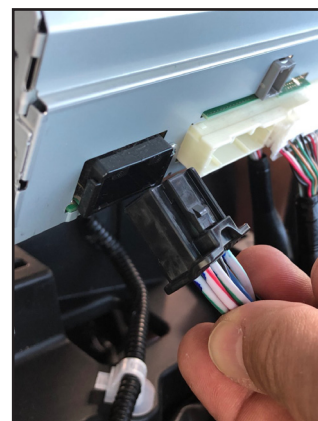

7. Pull out the radio and unplug the connectors.

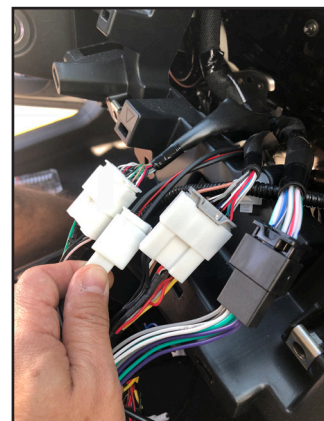

8. Mate the factory radio connectors to the SWRTY-61P T-harness. Test for functionality then install the aftermarket radio.



Factory bird's eye view and proximity sensors feature is retained.
 Image on the left is from a 2019 Toyota Camry using a Sony radio.



DIP SWITCH SETTINGS:

AFTERMARKET RADIO DIP SWITCH SETTINGS:

RADIO BRAND:	DIP:	1	2	3	4
Atoto, Dual, Farenheit, Jensen, Pioneer		OFF	OFF	ON	ON
Power Acoustik, Soundstream		OFF	OFF	ON	ON
Blaupunkt, Most off-brand Radios		OFF	OFF	ON	ON
Alpine		OFF	OFF	OFF	OFF
Clarion		OFF	ON	ON	OFF
Kenwood		OFF	ON	ON	ON
JVC		OFF	ON	OFF	ON
Boss, Old Sony		OFF	ON	OFF	OFF
New Sony		OFF	OFF	ON	OFF

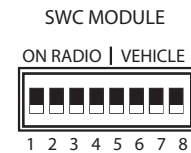

NOTE: For Atoto, Blaupunkt, Dual, Farenheit, Power Acoustik, Soundstream, and most off-brand radios, check the aftermarket radio's manual to see if the SWC buttons need to be programmed.

TOYOTA STEERING WHEEL CONTROL DIP SWITCH SETTING:

	DIP:	5	6	7	8
Toyota		OFF	ON	OFF	ON

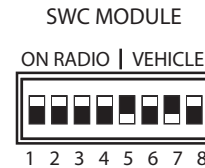

3.5MM SWC CABLE

Plug in the 3.5MM to 4-Pin SWC cable to the SWC module.

NOTE: Insulate the Blue/Yellow wire or 3.5mm plug if not being used.

For aftermarket radios that have wires for SWC connections, cut off the 3.5mm plug on the Crux SWC Cable and connect the SWC wires per the diagram on the right:



Note that there are some radios that only have SWC1 and SWC2, in this case "shield" does not need to be connected.

VEHICLE APPLICATIONS:

Toyota

2020-Up	4Runner	2019-Up	RAV4
2019-Up	Avalon	2020-Up	Sequoia
2018-Up	Camry	2018-Up	Sienna
2019-Up	CH-R	2020-Up	Tacoma
2018-Up	Corolla	2020-Up	Tundra
2020-Up	Highlander		

NOTE: For JBL amplified vehicles ONLY.

