

PRODUCT FEATURES:

- Retains factory features in select GM Class II Data Bus vehicles while functioning with an aftermarket radio.
- Supports Bose, Y-91 and non-amplified audio systems.
- Retains chime functions such as: seat belt, check engine, key in ignition, low fuel, low oil and lights on.
- Retains RAP (Retained Accessory Power).
- Double DIN Dash Kit included.
- EIA color coded wiring for easy installation.

PARTS INCLUDED:



DKGM-C2D MODULE



DKGM-C2D HARNESS



DOUBLE DIN DASH KIT

INSTALLATION DIAGRAM:

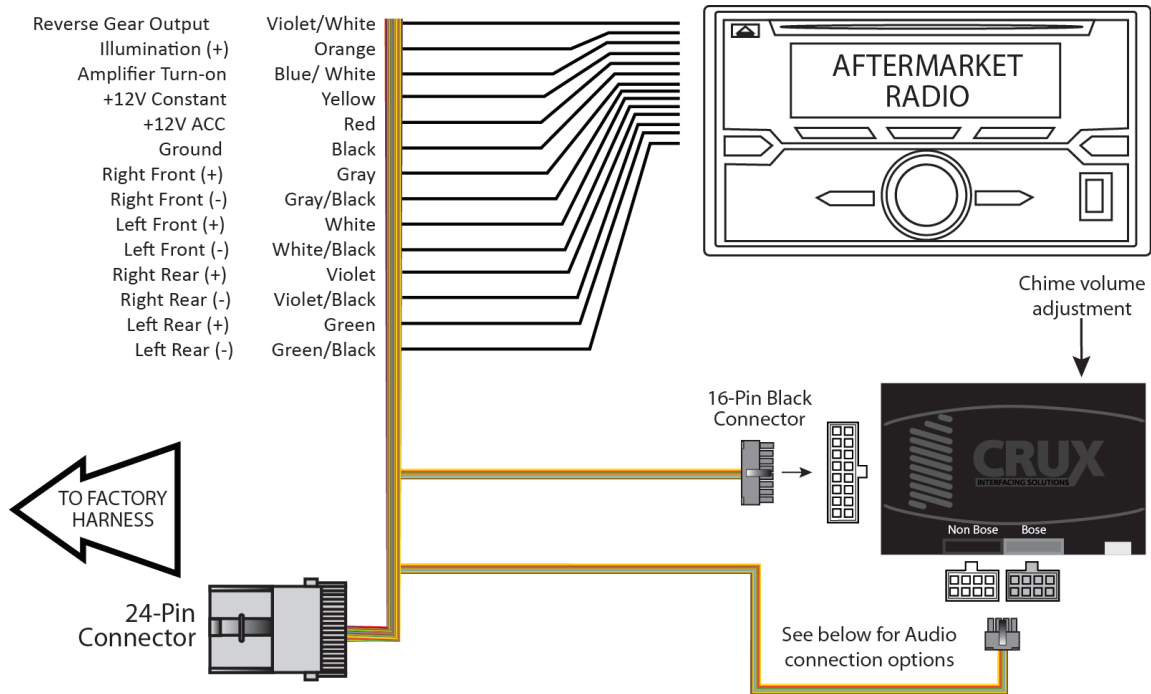

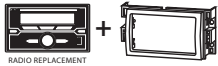

SELECTING THE AUDIO SYSTEM:

If the vehicle is equipped with an amplified audio system, the DKGM-C2D has a built-in audio level adaptor that outputs the proper audio level from the aftermarket radio to the factory amplifier. To use this feature, plug in the male 8-pin connector on the DKGM-C2D harness to the GRAY female 8-pin connector on the DKGM-C2D module. The module is also labeled “Bose” and “Non Bose” to avoid confusion. (see picture below)

If the vehicle is NOT equipped with a factory amplified system, plug in the male 8-pin connector to the BLACK female 8-pin on the DKGM-C2D module.



CHIME VOLUME ADJUSTMENT:

The DKGM-C2D has a potentiometer to adjust the chime volume. It is set at half way by default. To adjust the volume, simply use a suitable screw driver and turn the potentiometer clockwise to increase the volume and counter-clockwise to decrease the volume.

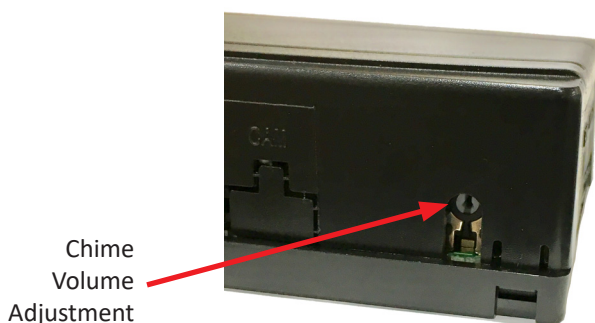



DASH KIT INSTALLATION:

Please make sure that you have all the parts as shown.

- (1) Main trim ring
- (1) Left ISO mounting bracket
- (1) Right ISO mounting bracket

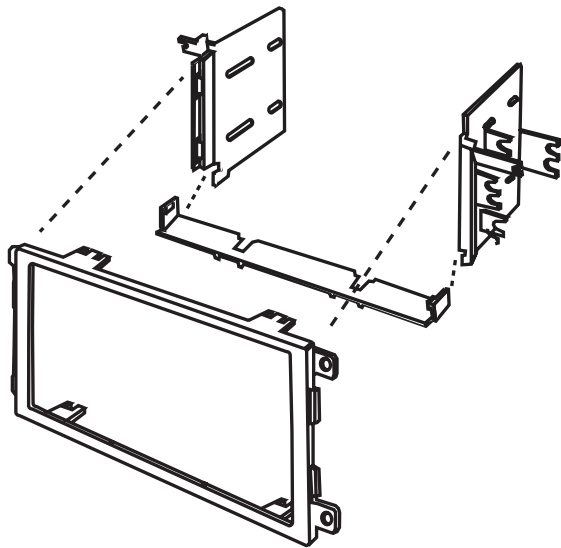
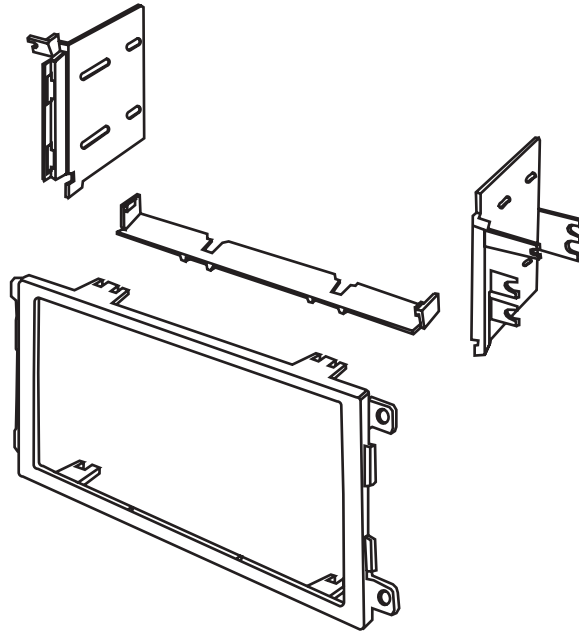

For some Cadillac installation, see diagram below:

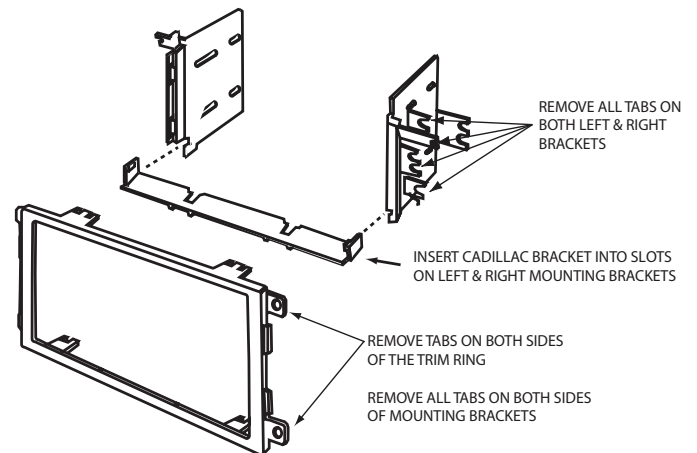

VEHICLE APPLICATIONS:

Buick

2004-2005 Century
2005-2007 LaCrosse
2004-2007 Rainier
2003-2005 Rendezvous
2005-2007 Terraza

Cadillac

2004-2006 Escalade

Chevrolet

2003-2006 Avalanche
2000-2005 Cavalier
2004-2013 Colorado
2006-2013 Corvette
2004-2007 Express
2000-2005 Impala
2000-2005 Monte Carlo
2003-2004 S-10
2003-2006 Silverado
2007 Silverado Classic
2003-2006 SSR
2003-2006 Suburban
2003-2006 Tahoe
2002-2009 Trailblazer
2005-2008 Uplander
2003-2005 Venture

GMC

2004-2011 Canyon
2002-2009 Envoy
2003-2007 Savana
2003-2006 Sierra
2007 Sierra Classic
2003-2006 Yukon

Hummer

2003-2007 H2
2005-2009 H3

Isuzu

2003-2008 Ascender
Oldsmobile
2001-2004 Alero
2002-2004 Bravada
2000-2004 Silhouette

Pontiac

2001-2005 Aztek
2001-2005 Grand Am
2004-2008 Grand Prix
2000-2006 Montana
2000-2005 Sunfire

Saab

2005-2008 9-7X
Saturn
2005-2007 Relay

NOTE:

There are instances on the Corvette when the chime will sound when either the "Traction Control" or the "DIC" (Driver Information Center) buttons are pressed.



Traction Control Button

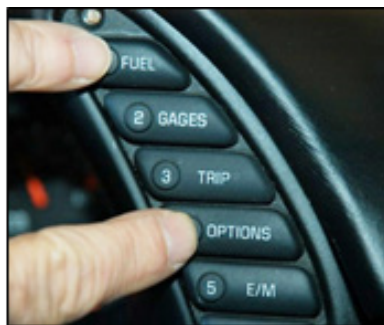

Driver Information Center Buttons

