



## PRODUCT FEATURES:

- Retains factory features in select Volkswagen vehicles while functioning with an aftermarket radio.
- Supports amplified and non-amplified systems.
- EIA color coded wiring for easy installation.
- Includes Single DIN/ISO with pocket or Double DIN Dash Kit.

## NOTES:

1. Driver information display will show the last information that was shown prior to removing the factory radio.
2. This interface does not retain the factory Bluetooth or Sirius Satellite Radio.
3. The radio is designed to shut off when the key is removed.
4. 2010 and Up vehicles with a premium sound system do not retain the RAP feature.

## PARTS INCLUDED:



Single DIN/ISO with pocket  
or Double DIN Dash Kit



SWRVW-52 Module



SWRVW-52 Harness



SWC Cables

## INSTALLATION DIAGRAM:

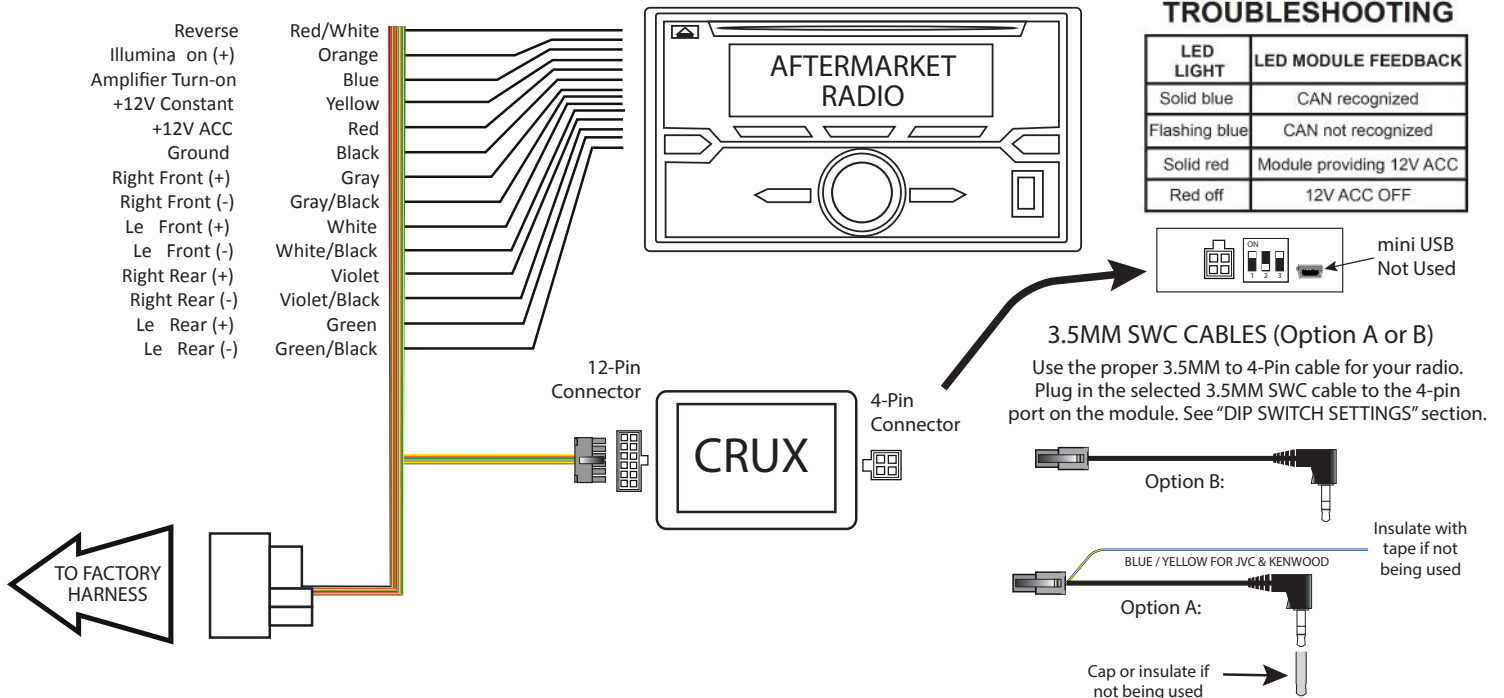



**DASH KIT ASSEMBLY DIAGRAM**

**DOUBLE DIN**

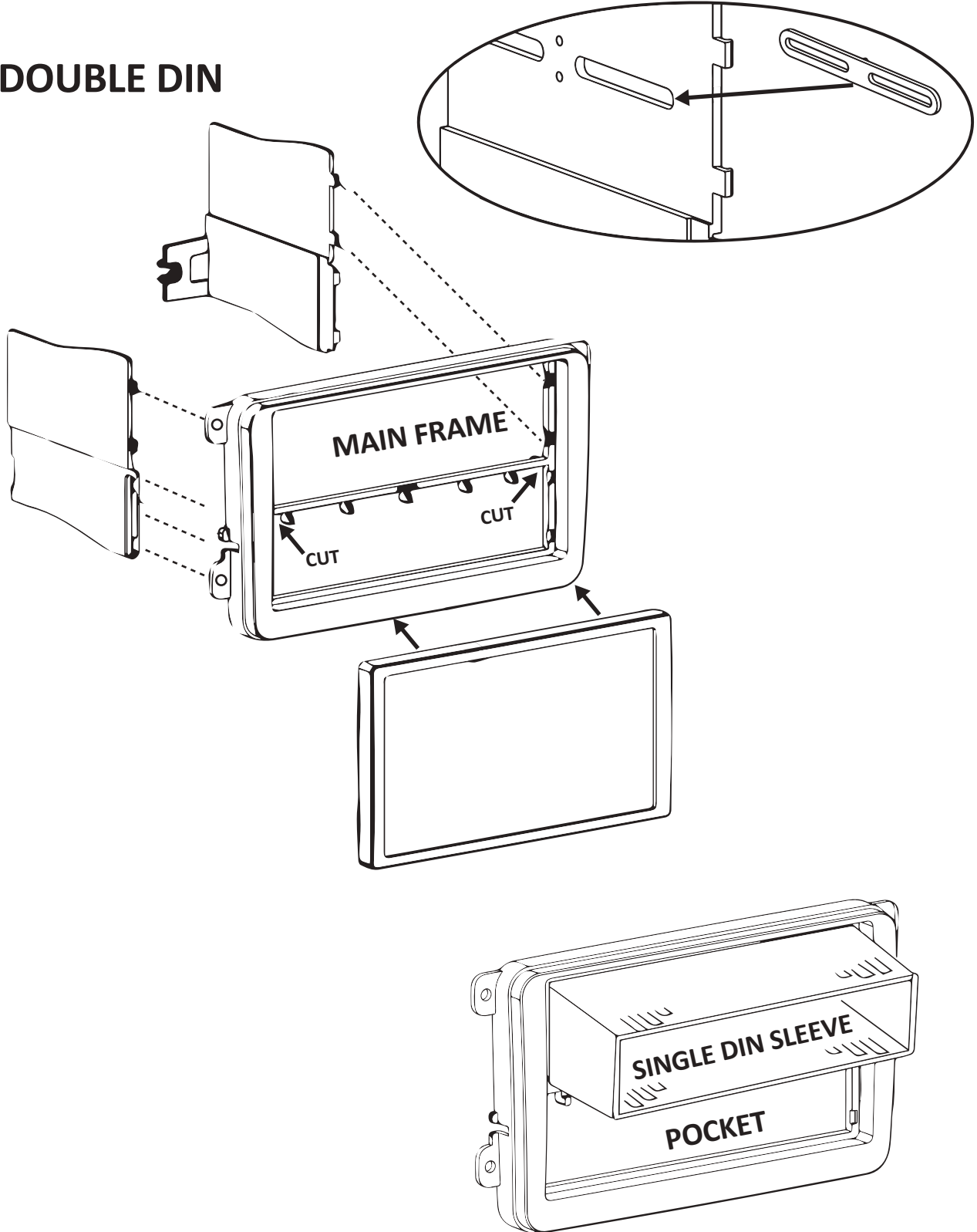



## DIP SWITCH SETTINGS:

### AFTERMARKET RADIO DIP SWITCH SETTINGS:

RADIO BRAND:	DIP#:	1	2	3
Atoto, Dual, Fahrenheit, Jensen		OFF	ON	ON
Pioneer, Power Acoustik, Soundstream		OFF	ON	ON
Blaupunkt, Most off-brand Radio		OFF	ON	ON
Alpine		OFF	OFF	OFF
Clarion		ON	ON	OFF
Kenwood		ON	ON	ON
JVC		ON	OFF	ON
Boss, Old Sony		ON	OFF	OFF
New Sony (with CarPlay)		OFF	ON	OFF

SWC MODULE  
DIP SWITCH



NOTE: For Atoto, Blaupunkt, Dual, Fahrenheit, Power Acoustik, Soundstream, and most off-brand radios, check the aftermarket radio's manual to see if the SWC buttons need to be programmed.

### 4-PIN SWC CABLE

Use the proper 3.5MM to 4-Pin SWC cable for the aftermarket radio you are using. The Blue/Yellow wire is for Kenwood and JVC radio SWC connection.

OPTION A is used for ALPINE, CLARION. JVC and KENWOOD will use the Blue/Yellow wire.  
OPTION B is used for ATOTO, BLAUPUNKT, BOSS, DUAL, FARENHEIT, JENSEN, POWER ACOUSTIK, PIONEER, SONY, SOUNDSTREAM and Most Off-Brand Radios.

NOTE: Cap or insulate the 3.5mm plug or Blue/Yellow wire if not being used.

For aftermarket radios that have wires for SWC connections, cut off the 3.5mm plug on the Crux SWC Cable and connect the SWC wires as follows:

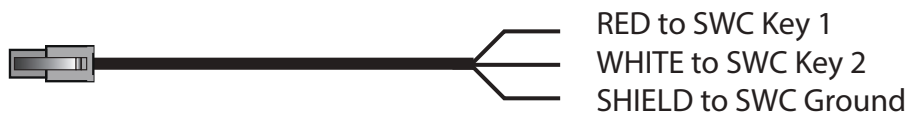

Note that there are some radios that only have SWC1 and SWC2, in this case "shield" does not need to be connected.

## VEHICLE APPLICATIONS:

### Volkswagen

2012 – 2013	Beetle	2006 – 2013	Passat
2009 – 2013	CC	2006 – 2009	Rabbit
2007 - 2012	EOS	2009 – 2014	Tiguan
2008 – 2013	Golf	2009 – 2010	Touareg
2006 – 2013	GTI		
2006 – 2013	Jetta		

