

PRODUCT FEATURES:

- Retains factory features in select Nissan vehicles while functioning with an aftermarket radio.
- Pre-programmed to retain factory Medium Speed CAN-Data Bus Steering Wheel Controls.
- Includes antenna adapter.
- Retains factory phone buttons.
- Retains factory USB input.
- Retains factory camera (not 360 panoramic camera).
- Provides outputs for Reverse & parking brake.
- Retains factory auxiliary input

PARTS INCLUDED:



SWRNS-63M MODULE



SWRNS-63M Harness



Antenna Adapter



SWC Cables



USB Retention Cable

INSTALLATION DIAGRAM FOR AMPLIFIED VEHICLES:

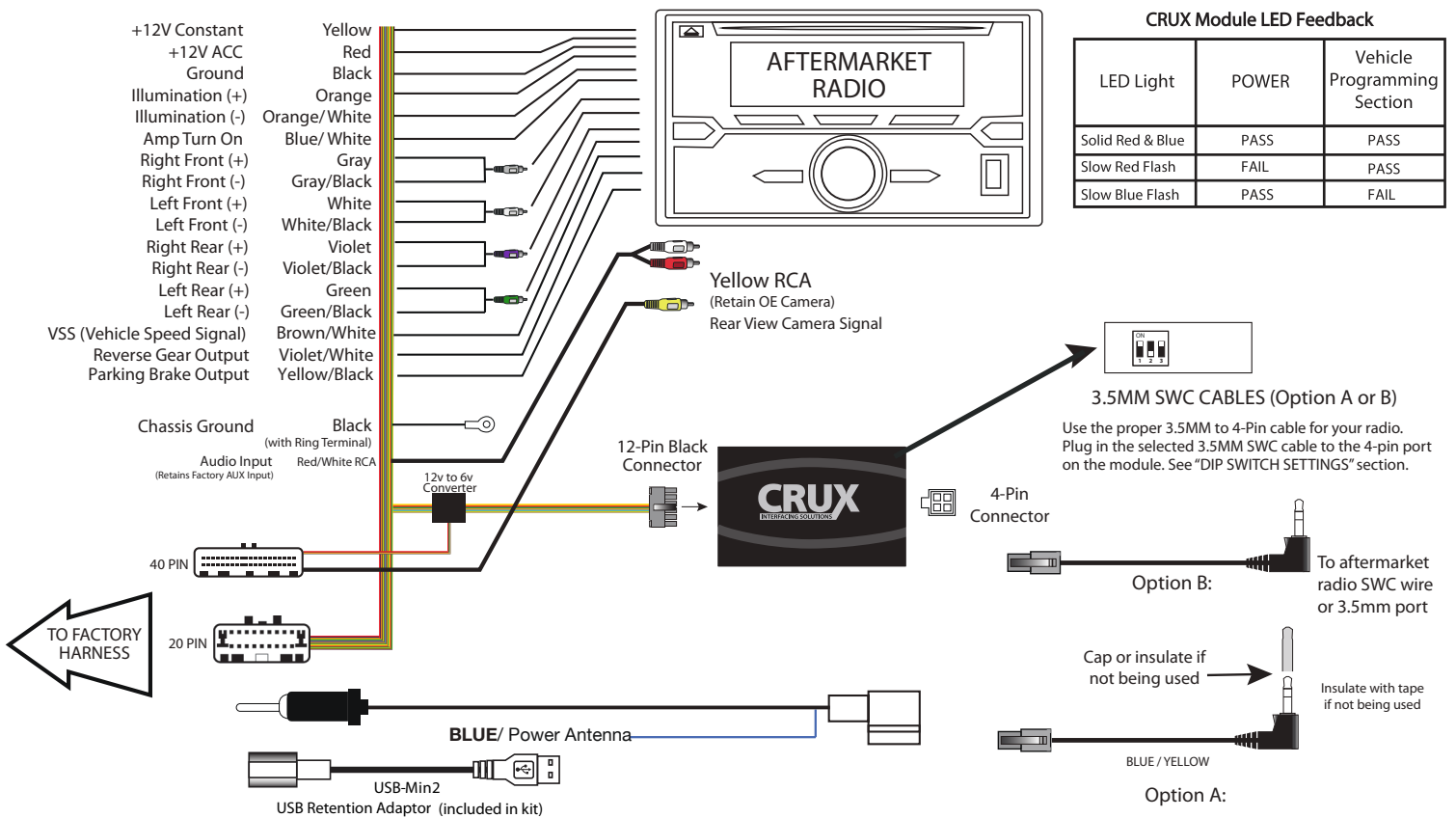

• For Amplified Systems Please Do Not Cut RCA to get better audio quality
** Please see page 2 for note



INSTALLATION DIAGRAM FOR NON-AMPLIFIED VEHICLES:

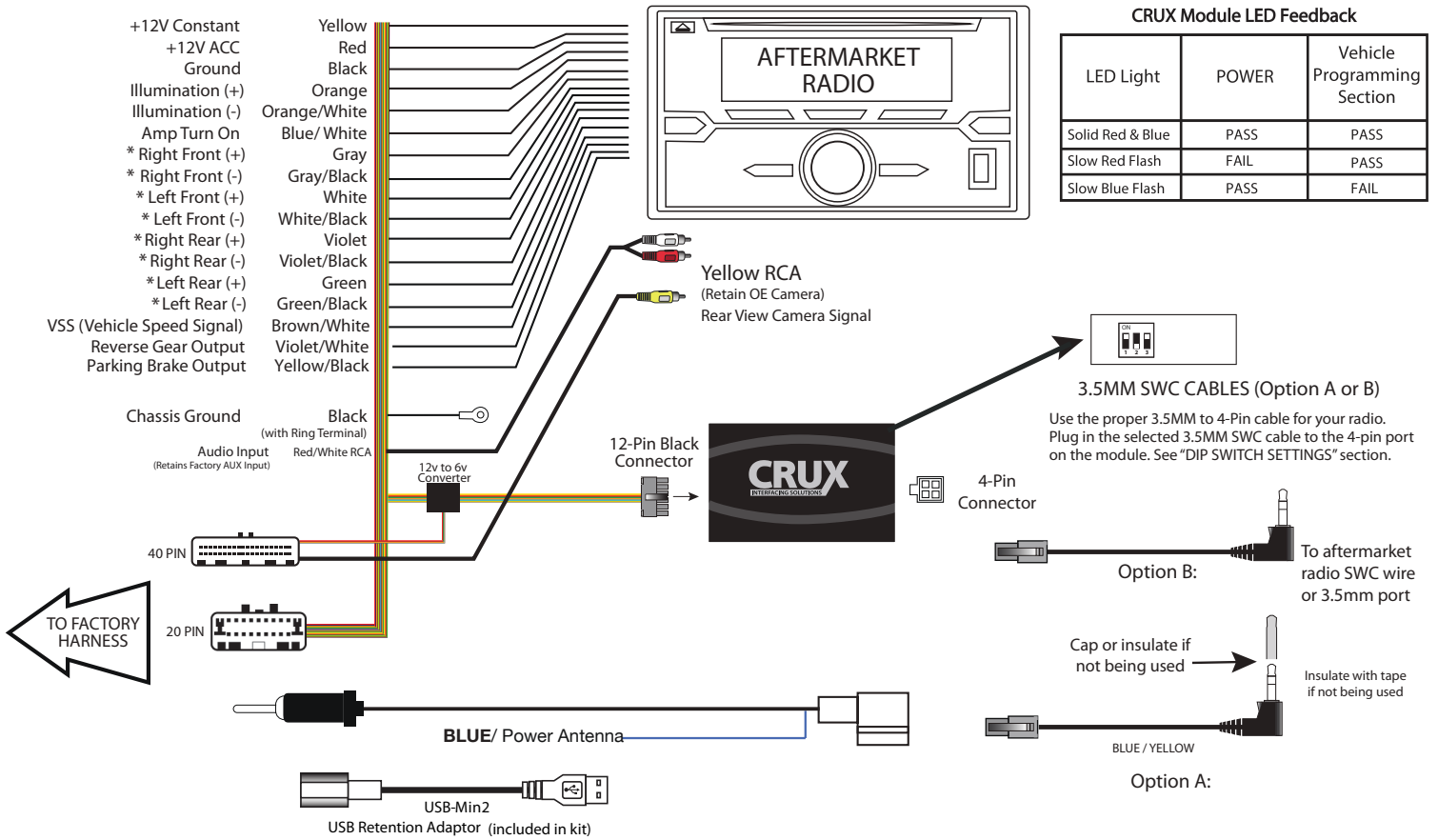

* For Non-Amplified systems please cut RCA , and mate colored wires to the appropriate aftermarket radio speaker wires

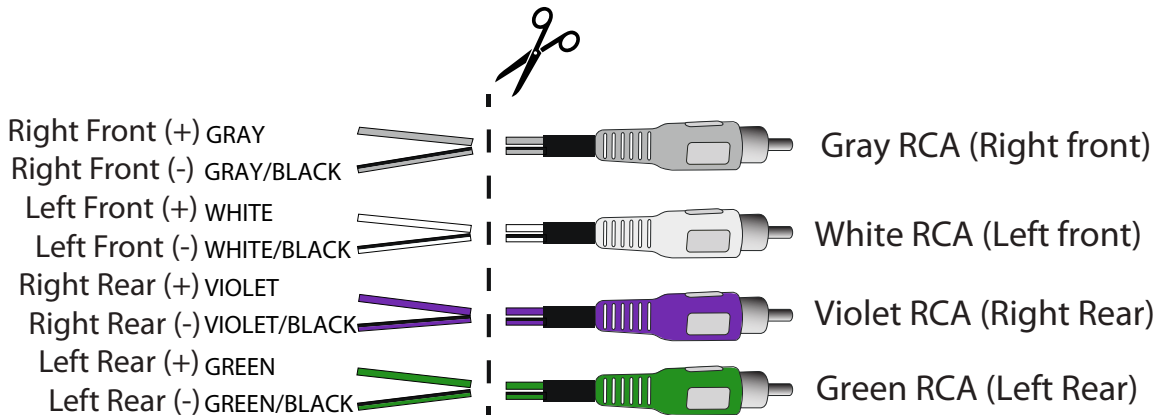

DIP SWITCH SETTINGS:

AFTERMARKET RADIO DIP SWITCH SETTINGS:

RADIO BRAND:	DIP#:	1	2	3
Atoto, Dual, Fahrenheit, Jensen, Nakamichi,		OFF	ON	ON
Pioneer, Power Acoustik, Soundstream		OFF	ON	ON
Blaupunkt, Most off-brand Radio		OFF	ON	ON
Alpine		OFF	OFF	OFF
Clarion, Stinger		ON	ON	OFF
Kenwood		ON	ON	ON
JVC		ON	OFF	ON
Boss, Old Sony		ON	OFF	OFF
New Sony (with CarPlay)		OFF	ON	OFF

SWC MODULE
DIP SWITCH



NOTE: For Atoto, Blaupunkt, Dual, Fahrenheit, Nakamichi, Power Acoustik, Soundstream, and most off-brand radios, check the aftermarket radio's manual to see if the SWC buttons need to be programmed.

4-PIN SWC CABLE

Use the proper 3.5MM to 4-Pin SWC cable for the aftermarket radio you are using.

OPTION A is used for ALPINE, CLARION, JVC, and KENWOOD units (Blue/Yellow wire is attached)
 OPTION B is used for ATOTO, BLAUPUNKT, BOSS, DUAL, FARENHEIT, JENSEN, POWER ACOUSTIK,
 PIONEER, SONY, SOUNDSTREAM and Most Off-Brand Radios.

NOTE: Cap or insulate the 3.5mm plug or Blue/Yellow wire if not being used.

For aftermarket radios that have wires for SWC connections, cut off the 3.5mm plug on the Crux SWC Cable (option B) and connect the SWC wires as follows:

Note that there are some radios that only have SWC1 and SWC2, in this case "shield" does not need to be connected.



RED to SWC Key 1
 WHITE to SWC Key 2
 SHIELD to SWC Ground

VEHICLE APPLICATIONS:

NISSAN

2015 - 2016 Murano Base radio w/ Nav w/o Bose

2015 - 2016 Murano w/ Bose w/ Nav

NOTE: For base radio w/ display & Non-Nav use CRUX Part #SWRNS-63S

NISSAN INFOTAINMENT WITH MAP AND CAMERA



NOTE: Some SWC functions might not be retained for the following radio series:
 Planet Audio P9900CPA, Jensen CAR 710, Atoto F7, and similar radios of these brands.

