

PRODUCT FEATURES:

- Retains factory features in select Nissan vehicles while functioning with an aftermarket radio.
- Pre-programmed to retain factory Medium Speed CAN-Data Bus Steering Wheel Controls.
- Retains Bose Amplifier.
- Retains factory USB & Auxiliary input .
- Retains factory camera (not 360 panoramic camera)
- Provides outputs for parking brake and reverse gear.

PARTS INCLUDED:



INSTALLATION DIAGRAM FOR AMPLIFIED VEHICLES:

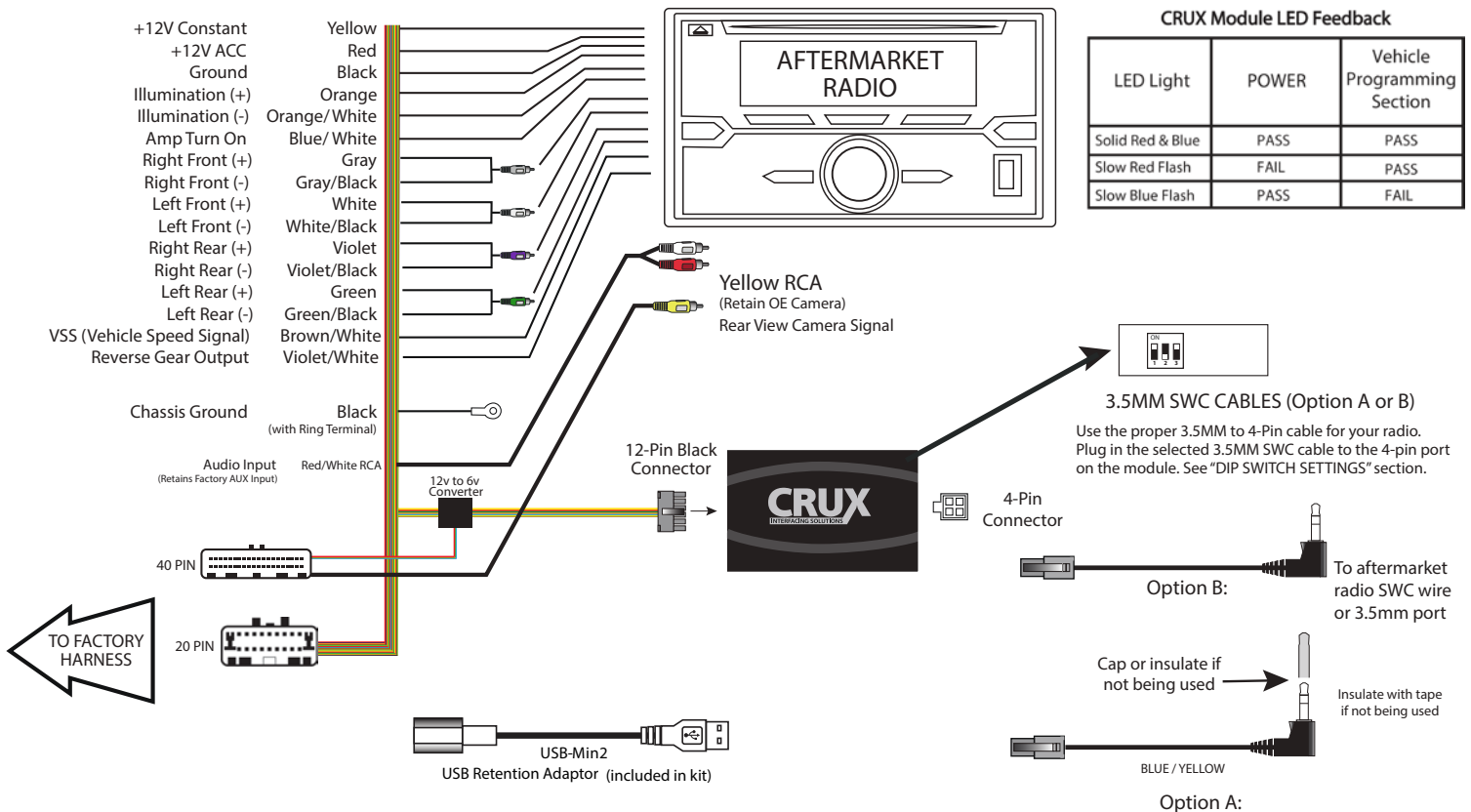

INSTALLATION DIAGRAM FOR NON-AMPLIFIED VEHICLES:

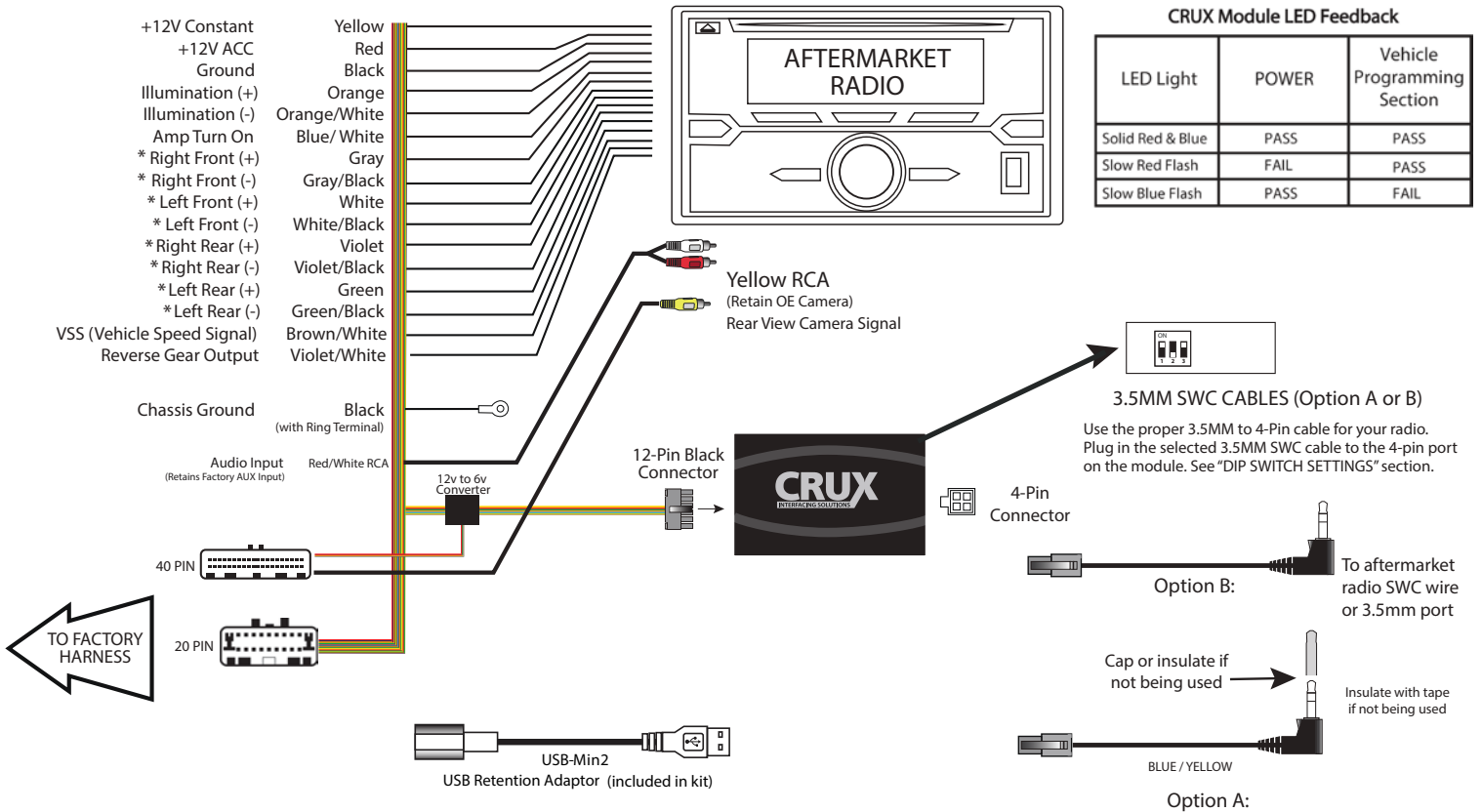

* For Non-Amplified systems please cut RCA , and mate colored wires to the appropriate aftermarket radio speaker wires

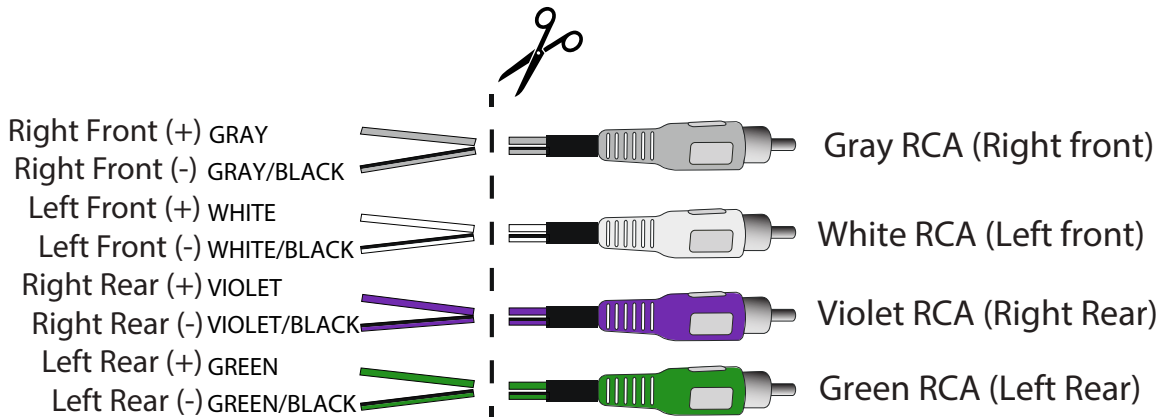

DIP SWITCH SETTINGS:

AFTERMARKET RADIO DIP SWITCH SETTINGS:

RADIO BRAND:	DIP#:	1	2	3
Atoto, Dual, Fahrenheit, Jensen, Nakamichi,		OFF	ON	ON
Pioneer, Power Acoustik, Soundstream		OFF	ON	ON
Blaupunkt, Most off-brand Radio		OFF	ON	ON
Alpine		OFF	OFF	OFF
Clarion, Stinger		ON	ON	OFF
Kenwood		ON	ON	ON
JVC		ON	OFF	ON
Boss, Old Sony		ON	OFF	OFF
New Sony (with CarPlay)		OFF	ON	OFF

SWC MODULE
DIP SWITCH



SWC Troubleshoot option

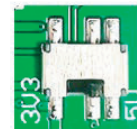

Located internally
Need to take plastic
Casing off module

- If Steering Wheel Controls don't work or work properly please switch internal dip switch from 3v3 to 5v as shown in picture above.

NOTE: For Atoto, Blaupunkt, Dual, Fahrenheit, Nakamichi, Power Acoustik, Soundstream, and most off-brand radios, check the aftermarket radio's manual to see if the SWC buttons need to be programmed.

4-PIN SWC CABLE

Use the proper 3.5MM to 4-Pin SWC cable for the aftermarket radio you are using.

OPTION A is used for ALPINE, CLARION, JVC, and KENWOOD units (Blue/Yellow wire is attached)
OPTION B is used for ATOTO, BLAUPUNKT, BOSS, DUAL, FARENHEIT, JENSEN, POWER ACOUSTIK, PIONEER, SONY, SOUNDSTREAM and Most Off-Brand Radios.

NOTE: Cap or insulate the 3.5mm plug or Blue/Yellow wire if not being used.

For aftermarket radios that have wires for SWC connections, cut off the 3.5mm plug on the Crux SWC Cable (option B) and connect the SWC wires as follows:

Note that there are some radios that only have SWC1 and SWC2, in this case "shield" does not need to be connected.



RED to SWC Key 1
WHITE to SWC Key 2
SHIELD to SWC Ground

VEHICLE APPLICATIONS:

NISSAN

2019 and Up Sentra w/CarPlay w/ Bose
2019 and Up Sentra w/ CarPlay w/o Bose

Note: With out CarPlay, 40 & 20 pin connectors use CRUX Part #SWRNS-63F

Radio Buttons will be on the left.

Please look out for this home screen layout for this part.

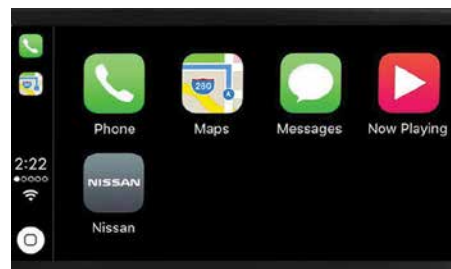

NOTE: Some SWC functions might not be retained for the following radio series:
Planet Audio P9900CPA, Jensen CAR 710, Atoto F7, and similar radios of these brands.



STEERING WHEEL CONTROL TROUBLE SHOOTING:

Note: Identify Alpine SWC learning radios by checking for three SWC cables and a SWC learn menu, instead of a 3.5mm SWC input.

If Interface has one SWR-100 Cable included

If Interface has two SWR Cables included

1 - Find the included SWC adapter cable.

1 - Identify appropriate SWC adapter cable.
Do not use cable with Blue / Yellow wire.

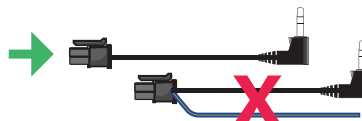

2 - Prepare the SWC Cable: Cut the SWC cable. You will find a red wire, a white wire, and a ground (shield) wire inside.

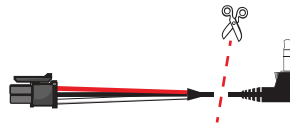

3 - Adjust the Module Settings: Set the module to the Pioneer dip switch setting. This configures the module to communicate correctly with the Alpine radio.

DIP: 1 2 3
On Alpine iLX series radios use Pioneer settings | OFF | ON | ON



4 - Configure the Alpine Radio: On your Alpine radio, select the setting that includes an adapter for SWC. This ensures the radio will recognize the steering wheel controls.

Select "SWC Adapter"



Select the setting "With Adapter"

5 - Connect the Wires: Connect both the SWC1 and SWC2 wires from aftermarket radio to the red wire from our SWC cable. Connect the SWC ground wire to the shield (ground) wire of our SWC cable. These steps should enable the steering wheel controls on your Alpine iLX series radio.

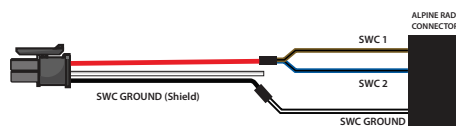
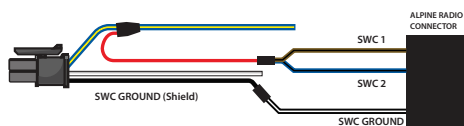

6. Program the SWC: Navigate to the SWC settings on your Alpine radio to assign and test each control function.



ALTERNATIVE ACCESSORY POWER TROUBLE SHOOTING:

Note: If you are experiencing issues with accessory power from the module, connect the provided alternative power wire to the CRUX connector and then to the aftermarket radio



HARNESS VIEW

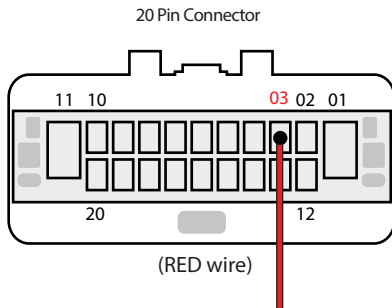

For Vehicles with **PUSH START** ignition

For 2019 NISSAN SENTRA with Push Start with Nav & Car Play:

Attach the provided red wire to pin 03 on the CRUX 20-pin connector.

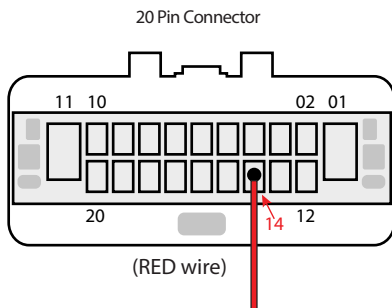

For Vehicles with **STANDARD KEY**

For 2019 NISSAN SENTRA with Nav & Car Play:

Attach the provided red wire to pin 14 on the CRUX 20-pin connector.

