

PRODUCT FEATURES:

- Retains factory features in select Honda vehicles while functioning with an aftermarket radio.
- Pre-programmed to retain factory Steering Wheel Controls.
- Provides navigational outputs: Reverse, Illumination, Parking Brake, Vehicle Speed Sense & Lanewatch Camera Outputs.
- Retains factory Multi-Angle Rear View Camera & Lanewatch Camera, & Auxiliary Input.
- Includes antenna adapter & USB retention cable.

NOTES:

1. Supports both Amplified & Non-amplified vehicles.
2. Does not retain Rear Seat Entertainment system (RSE).
3. Includes Crux Video Switcher to Lanewatch and rear view camera retention.
3. If vehicle does not have Lanewatch camera interface can still be used.

PARTS INCLUDED:



INSTALLATION DIAGRAM FOR AMPLIFIED VEHICLES WITH LANE WATCH CAMERA:

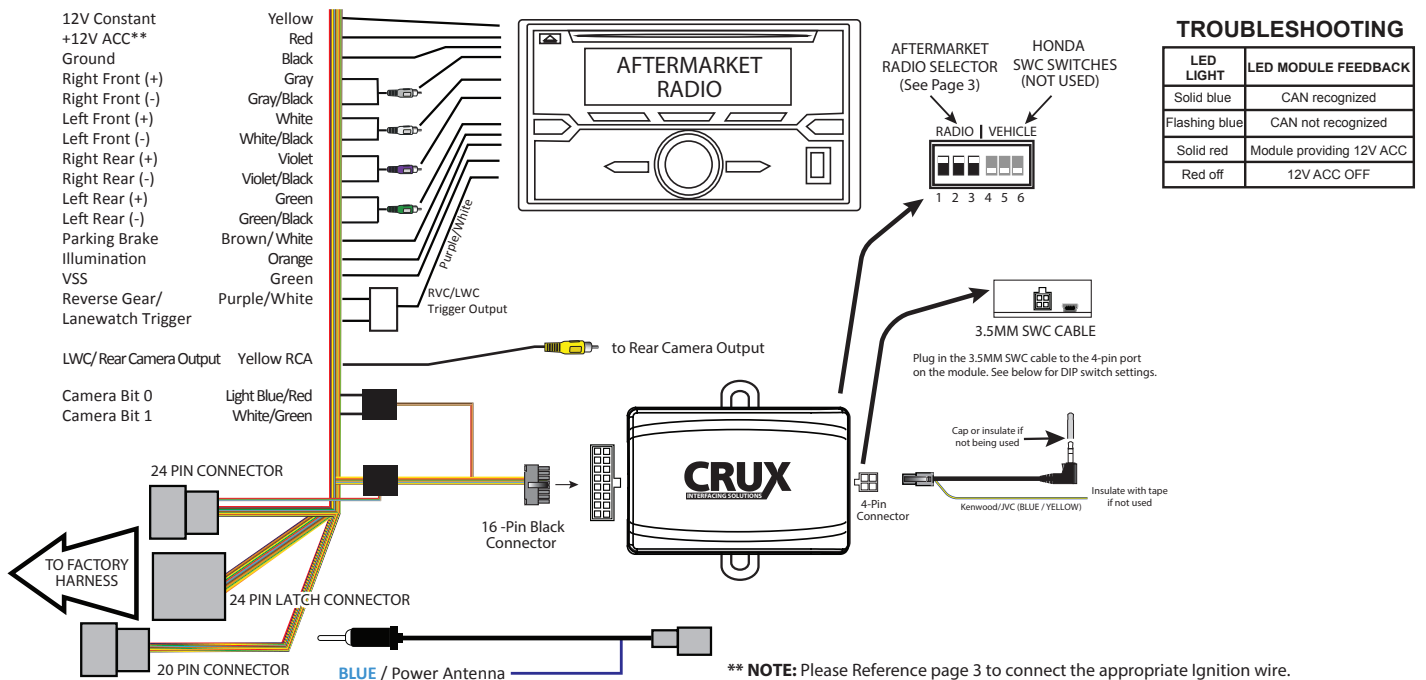

INSTALLATION DIAGRAM FOR NON-AMPLIFIED VEHICLES WITH LANE WATCH CAMERA:

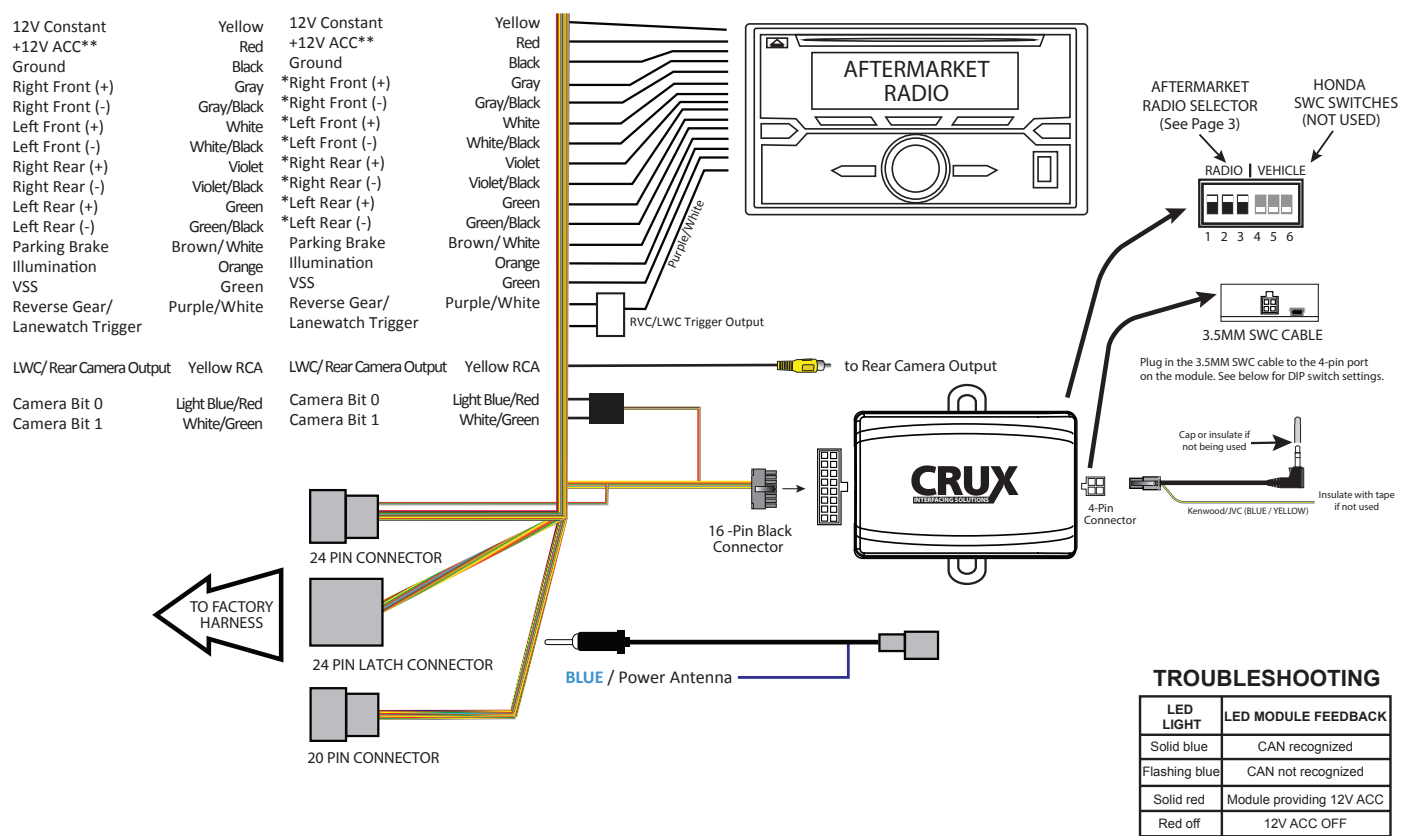

**** NOTE:** Please Reference page 3 to connect the appropriate Ignition wire.

* For Non-Amplified systems please cut RCA , and mate colored wires to the appropriate aftermarket radio speaker wires

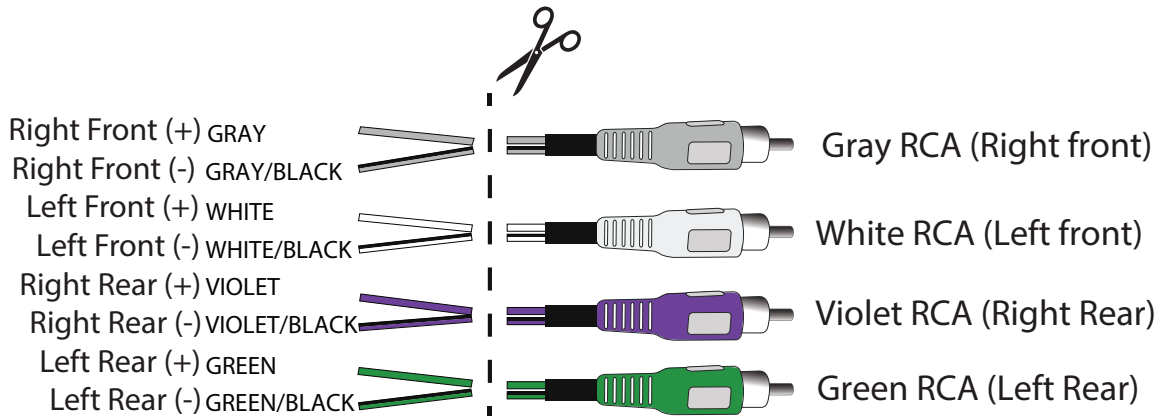

ALTERNATIVE ACCESSORY POWER TROUBLE SHOOTING:

Note: If you are experiencing issues with accessory power from the module, connect the provided alternative power wire to the CRUX connector and then to the aftermarket radio



HARNESS VIEW

For Vehicles with STANDARD KEY

If your vehicle uses a regular key, connect the red accessory wire using the 2-pin female Molex connector to the matching 2-pin male Molex connector as shown in the diagram, then connect the wire to the aftermarket radio.

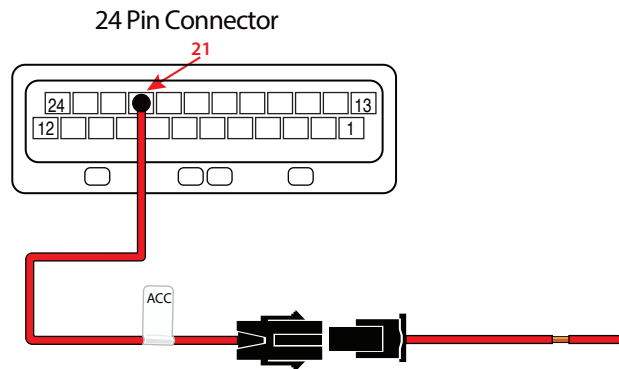
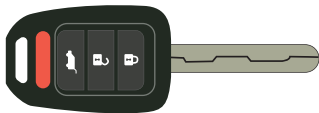

For Vehicles with PUSH START ignition

If your vehicle has a push-start button, connect the red/black Ignition ACC wire using the 2-pin female Molex connector to the matching 2-pin male Molex connector as shown in the diagram, then connect the wire to the aftermarket radio.

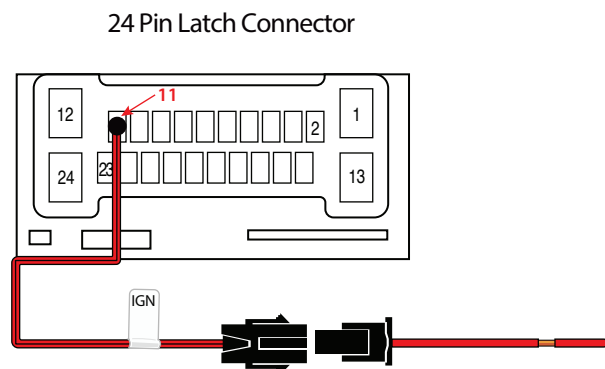

DIP SWITCH SETTINGS:

AFTERMARKET RADIO DIP SWITCH SETTINGS:

RADIO BRAND:	DIP#:	1	2	3
Atoto, Dual, Fahrenheit, Jensen, Nakamichi,		OFF	ON	ON
Pioneer, Power Acoustik, Soundstream		OFF	ON	ON
Blaupunkt, Most off-brand Radio		OFF	ON	ON
Alpine		OFF	OFF	OFF
Clarion		ON	ON	OFF
Kenwood		ON	ON	ON
JVC		ON	OFF	ON
Boss, Old Sony		ON	OFF	OFF
New Sony (with CarPlay)		OFF	ON	OFF

SWC MODULE
DIP SWITCH



NOTE:
DIP SWITCHES
4 - 6 ARE NOT
USED

SWC Troubleshoot option

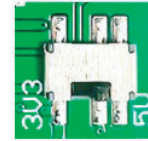

Located internally
Need to take plastic
Casing off module

- If Steering Wheel Controls don't work or work properly please switch internal dip switch from 3v3 to 5v as shown in picture above.

NOTE: For Atoto, Blaupunkt, Dual, Fahrenheit, Nakamichi, Power Acoustik, Soundstream, and most off-brand radios, check the aftermarket radio's manual to see if the SWC buttons need to be programmed.

4-PIN SWC CABLE

Use the proper 3.5MM to 4-Pin SWC cable for the aftermarket radio you are using.

OPTION A is used for ALPINE, CLARION. Use the Blue/Yellow wire for JVC and KENWOOD units.
 OPTION B is used for ATOTO, BLAUPUNKT, BOSS, DUAL, FARENHEIT, JENSEN, POWER ACOUSTIK, PIONEER, SONY, SOUNDSTREAM and Most Off-Brand Radios.

NOTE: Cap or insulate the 3.5mm plug or Blue/Yellow wire if not being used.

For aftermarket radios that have wires for SWC connections, cut off the 3.5mm plug on the Crux SWC Cable (option B) and connect the SWC wires as follows:

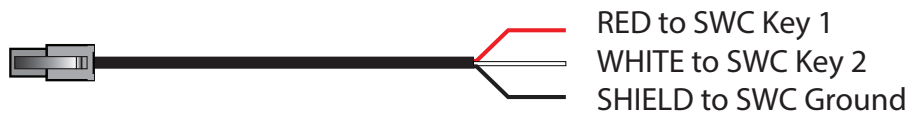

Note that there are some radios that only have SWC1 and SWC2, in this case "shield" does not need to be connected.

VEHICLE APPLICATIONS:

- 2012- 2016 HONDA CIVIC
- 2015- Up HONDA CRV
- 2015- 2017 HONDA FIT (w/touchscreen)



MULTI-ANGLE REAR VIEW CAMERA

The Crux SWRHN-62CV retains the factory Multi-Angle Rearview Camera functionality. Use the factory source button on the steering to switch between the available camera views. Follow steps below.



Place vehicle in reverse for Default camera view



For wide angle view press source button for 1 second



For top down camera view press source button for 1 second



LANE WATCH CAMERA RETENTION INSTALLATION:

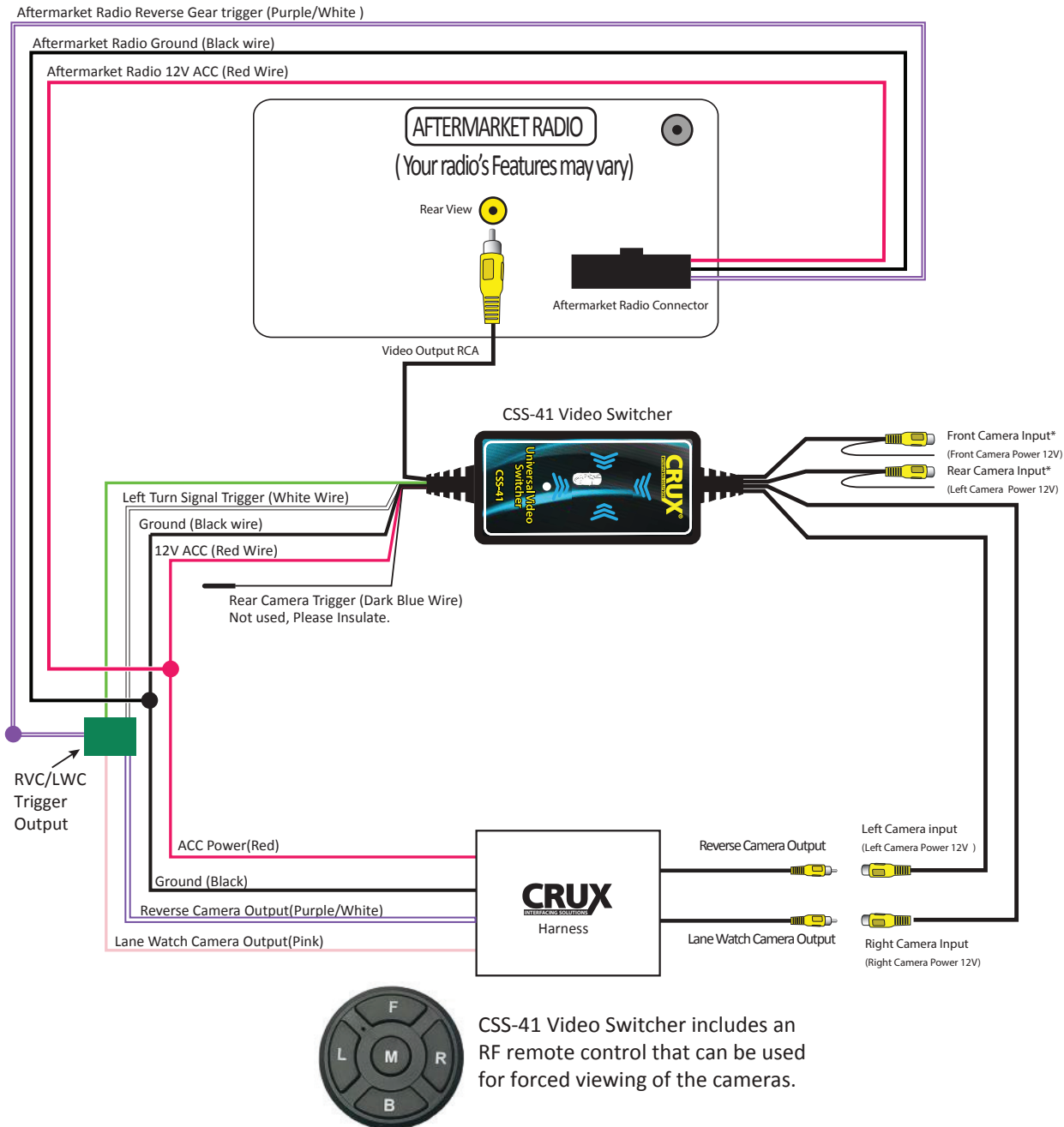



NOTE:

- The CSS-41's Red 12V Accessory wire and Black Ground wire should be connected to both the aftermarket radio's accessory and ground wires as well as the main harness accessory and ground wires—forming a three-way connection.
- Front Camera Input and Left Camera Input are not used to retain OEM lane watch camera, but can be used to add additional cameras
- CR2016 battery required for RF remote. Battery must be purchased separately.

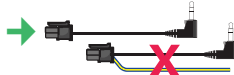

STEERING WHEEL CONTROL TROUBLE SHOOTING:

Note: Identify Alpine SWC learning radios by checking for three SWC cables and a SWC learn menu, instead of a 3.5mm SWC input.

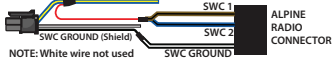
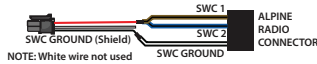
If Interface has one SWR-100 Cable included	If Interface has two SWR Cables included
<p>1 - Find the included SWC adapter cable.</p> 	<p>1 - Identify appropriate SWC adapter cable. Do not use cable with Blue / Yellow wire.</p> 
<p>2 - Prepare the SWC Cable: Cut the SWC cable. You will find a red wire, a white wire, and a ground (shield) wire inside.</p> 	
<p>3 - Adjust the Module Settings: Set the module to the Pioneer dip switch setting. This configures the module to communicate correctly with the Alpine radio.</p>	
<p>4 - Configure the Alpine Radio: On your Alpine radio, select the setting that includes an adapter for SWC. This ensures the radio will recognize the steering wheel controls.</p>	
<p>5 - Connect the Wires: Connect both the SWC1 and SWC2 wires from aftermarket radio to the red wire from our SWC cable. Connect the SWC ground wire to the shield (ground) wire of our SWC cable. These steps should enable the steering wheel controls on your Alpine iLX series radio.</p>	
 <p>NOTE: White wire not used</p>	 <p>NOTE: White wire not used</p>
<p>6. Program the SWC: Navigate to the SWC settings on your Alpine radio to assign and test each control function.</p>	

