



SWRCR-59LV

Radio Replacement w/ SWC & Digital Camera Retention for
Select Dodge, Fiat, Jeep & Ram Vehicles

PRODUCT MANUAL
VER.032326

CONTACT

ADDRESS:

CRUX Interfacing Solutions
21541 Nordhoff St. Unit C,
Chatsworth, CA 91311

PHONE:

(818) 609-9299

E-MAIL:

support@cruxinterfacing.com
sales@cruxinterfacing.com

WEBSITE:

www.cruxinterfacing.com

PRODUCT FEATURES:

- Retains factory features in select Dodge, Fiat, Jeep and RAM vehicles while functioning with an aftermarket radio.
- Retains Steering Wheel Controls via built-in, pre-programmed interface.
- Provides accessory power (2A Max).
- Retains factory backup camera (composite and LVDS)
- Retains factory Aux input in select vehicles.
- Retains factory SWC phone button functionality in select vehicles.
- Retains factory Digital (Alpine amplifier) and analog amplifier.
- EIA color coded wiring for easy installation.

PARTS INCLUDED:



INSTALLATION DIAGRAM:

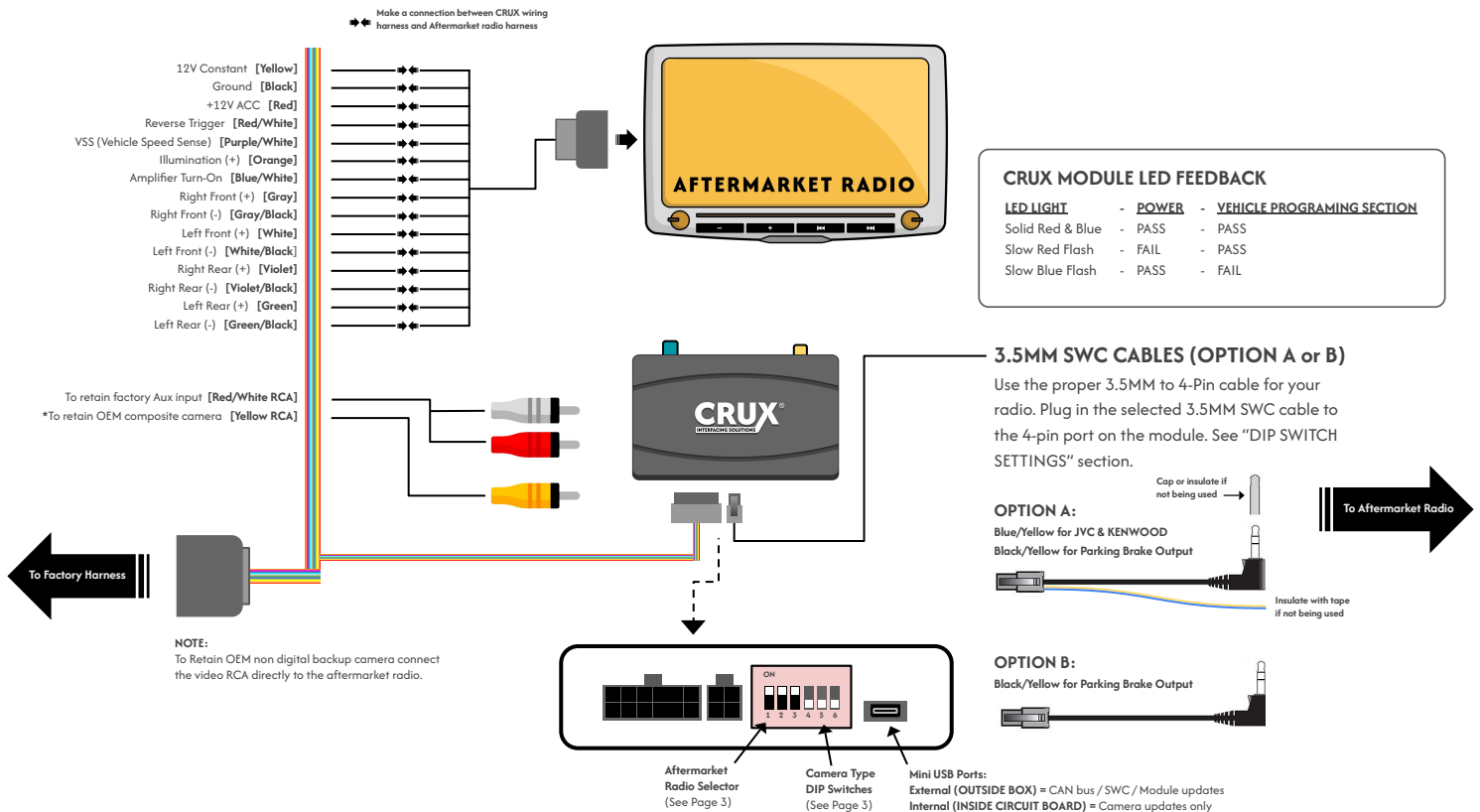

DIGITAL CAMERA RETENTION INSTRUCTIONS:

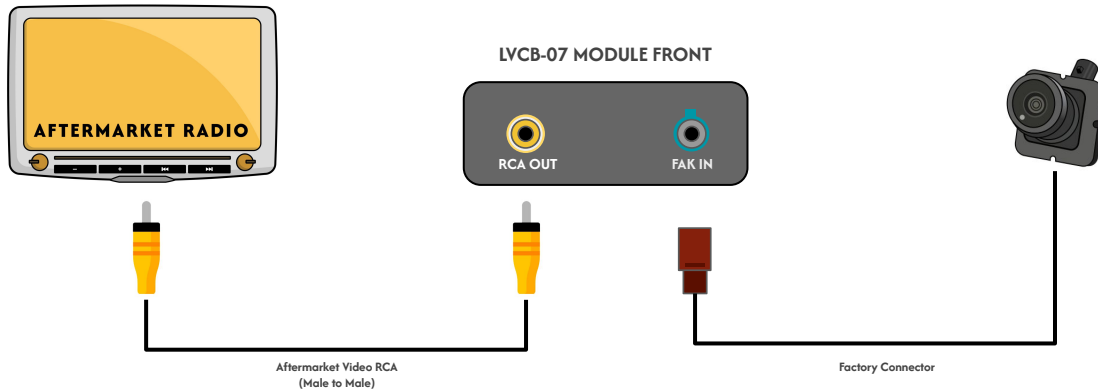

DIP SWITCH SETTINGS:

AFTERMARKET RADIO DIP Switch Settings

RADIO BRAND:	DIP#:	1	2	3	4*	5*	6*
Atoto, Dual, Fahrenheit, Jensen, Nakamichi		OFF	ON	ON	ON/OFF	ON/OFF	ON/OFF
Pioneer, Power Acoustik, Soundstream		OFF	ON	ON	ON/OFF	ON/OFF	ON/OFF
Blaupunkt, Most off-brand Radio		OFF	ON	ON	ON/OFF	ON/OFF	ON/OFF
Alpine		OFF	OFF	OFF	ON/OFF	ON/OFF	ON/OFF
Clarion		ON	ON	OFF	ON/OFF	ON/OFF	ON/OFF
Kenwood		ON	ON	ON	ON/OFF	ON/OFF	ON/OFF
JVC		ON	OFF	ON	ON/OFF	ON/OFF	ON/OFF
BOSS, Old Sony		ON	OFF	OFF	ON/OFF	ON/OFF	ON/OFF
New Sony (with CarPlay)		OFF	ON	OFF	ON/OFF	ON/OFF	ON/OFF

NOTE: For Atoto, Blaupunkt, Dual, Fahrenheit, Nakamichi, Power Acoustik, Soundstream, and most off-brand radios. Check the aftermarket radio's manual to see if the SWC buttons need to be programmed

SWC TROUBLESHOOTING OPTION



Located internally, need to take plastic casing off module

If Steering Wheel Controls don't work or work properly, please switch internal DIP switch from 3v3 to 5v as shown in picture above.

CAMERA TYPE DIP Switch Settings

CAMERA VERSION*	DIP#:	4*	5*	6*
Small Resolution (7" UConnect UAG)		OFF	OFF	OFF
Large Resolution (8.4" UConnect UAS/UAQ)		ON	OFF	OFF
Camera Type 3 (ProMaster 5" UConnect UAA)		OFF	ON	OFF

RAM Applications (2019+):

- 5" (UAA)
- 7" (UAG)
- 8.4" (UAS = without Navigation / UAQ = with Navigation)
- 12" (Uconnect 4C NAV)

Jeep Applications:

- 7" Uconnect (UAG)
- 8.4" Uconnect (UAS = without Navigation / UAQ = with Navigation)



NOTE:

After each change of the DIP switch settings you have to execute a power reset of the interface box.

Use the proper 3.5MM to 4-PIN SWC cable for the aftermarket radio that is being used. Plug the 4-PIN Molex Connector to the SWRCR-59D module and connect the 3.5MM plug or Blue/Yellow wire to the aftermarket radio's SWC input.

OPTION A is used for ALPINE, CLARION, (JVC and KENWOOD units will use the Blue/Yellow wire).

OPTION B is used for ATOTO, BOSS, BLAUPUNKT, DUAL, FARENHEIT, JENSEN, POWER ACOUSTIK, PIONEER, SONY, SOUNDSTREAM, and most off-brand units.

For aftermarket radios that have wires for SWC connections, cut off the 3.5mm plug on the Crux SWC Cable (option B) and connect the SWC wires as follows:



Note that there are some radios that only have SWC1 and SWC2, in this case "shield" does not need to be connected.

VEHICLE APPLICATIONS:

YEARS	MAKE	MODEL	YEARS	MAKE	MODEL
2014 - 2016	DODGE	DART	2014 - 2020	FIAT	500L
2015 - 2022	DODGE	CHALLENGER	2016 - 2020	FIAT	500X
2015 - 2022	DODGE	CHARGER	2013 - 2017	RAM	1500
2014 - 2021	DODGE	DURANGO	2018 - 2022	RAM	1500*
2014 - 2015	JEEP	CHEROKEE	2013 - 2017	RAM	2500
LATE 2017 - 2020	JEEP	COMPASS	2018 - 2021	RAM	2500*
2021 - UP	JEEP	COMPASS**	2013 - 2017	RAM	3500
2014 - 2015	JEEP	GRAND CHEROKEE	2018 - 2021	RAM	3500*
2015 - 2021	JEEP	RENEGADE**	2014 - 2020	RAM	PROMASTER
2022 - UP	JEEP	RENEGADE	2021	RAM	PROMASTER*
2018 - 2022	JEEP	WRANGLER (JL MODEL)*			
2020 - UP	JEEP	GLADIATOR*			

NOTES:

Applications with an (*) may be equipped with the OEM LVDS digital camera. Please use the module to convert the digital signal to composite to retain the factory camera.

New model RAM and Jeep vehicles with 32 & 13 PIN Connectors use part #SWRCR-59T
Does NOT retain Beats Audio System.

For Fiat:

1. Will NOT retain backup sensor on Fiat vehicles (if equipped).
2. Once factory radio is removed, the outside temperature will no longer be present on the cluster.

For RAM ProMaster:

1. Will NOT retain Phone and Voice button.

**Some Jeep Renegade & Jeep Compass vehicles have an issue with the factory dashboard so door chimes, interior/alarm, turn signals, & hazard audible chimes do not work or are inaudible. Therefore, when you use this interface those issues will still persist. This is a factory speaker wire issue NOT SWRCR-59LV interface.



2020 Jeep Wrangler



2020 RAM 1500