



---

# SWRHN-62HV

Radio Replacement w/ SWC & Multi-Angle Rear View Camera Retention for  
Select 2015 - 2019 Honda Vehicles

---

**PRODUCT MANUAL**  
**VER.032426**

---

## CONTACT

**ADDRESS:**

**CRUX Interfacing Solutions**  
21541 Nordhoff St. Unit C,  
Chatsworth, CA 91311

**PHONE:**

(818) 609-9299

**E-MAIL:**

support@cruxinterfacing.com  
sales@cruxinterfacing.com

**WEBSITE:**

[www.cruxinterfacing.com](http://www.cruxinterfacing.com)

## PRODUCT FEATURES:

- Retains factory features in select Honda vehicles while functioning with an aftermarket radio.
- Pre-programmed to retain factory Steering Wheel Controls.
- Retains factory multi-angle rear view camera.
- Retains factory Auxiliary input.
- Includes antenna adapter & USB retention cable.
- EIA color coded wiring for easy installation.

**NOTE:**

- 1.) Does **NOT** support amplified systems.
- 2.) Does **NOT** retain Rear Seat Entertainment system (RSE).

## PARTS INCLUDED:

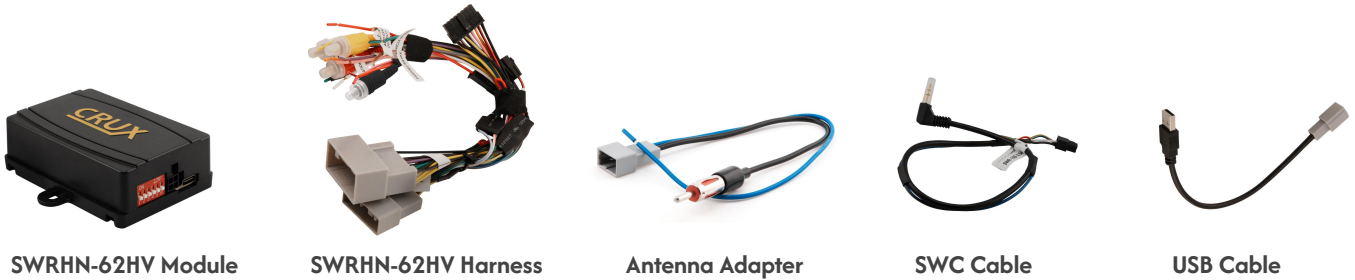

SWRHN-62HV Module

SWRHN-62HV Harness

Antenna Adapter

SWC Cable

USB Cable

## INSTALLATION DIAGRAM:

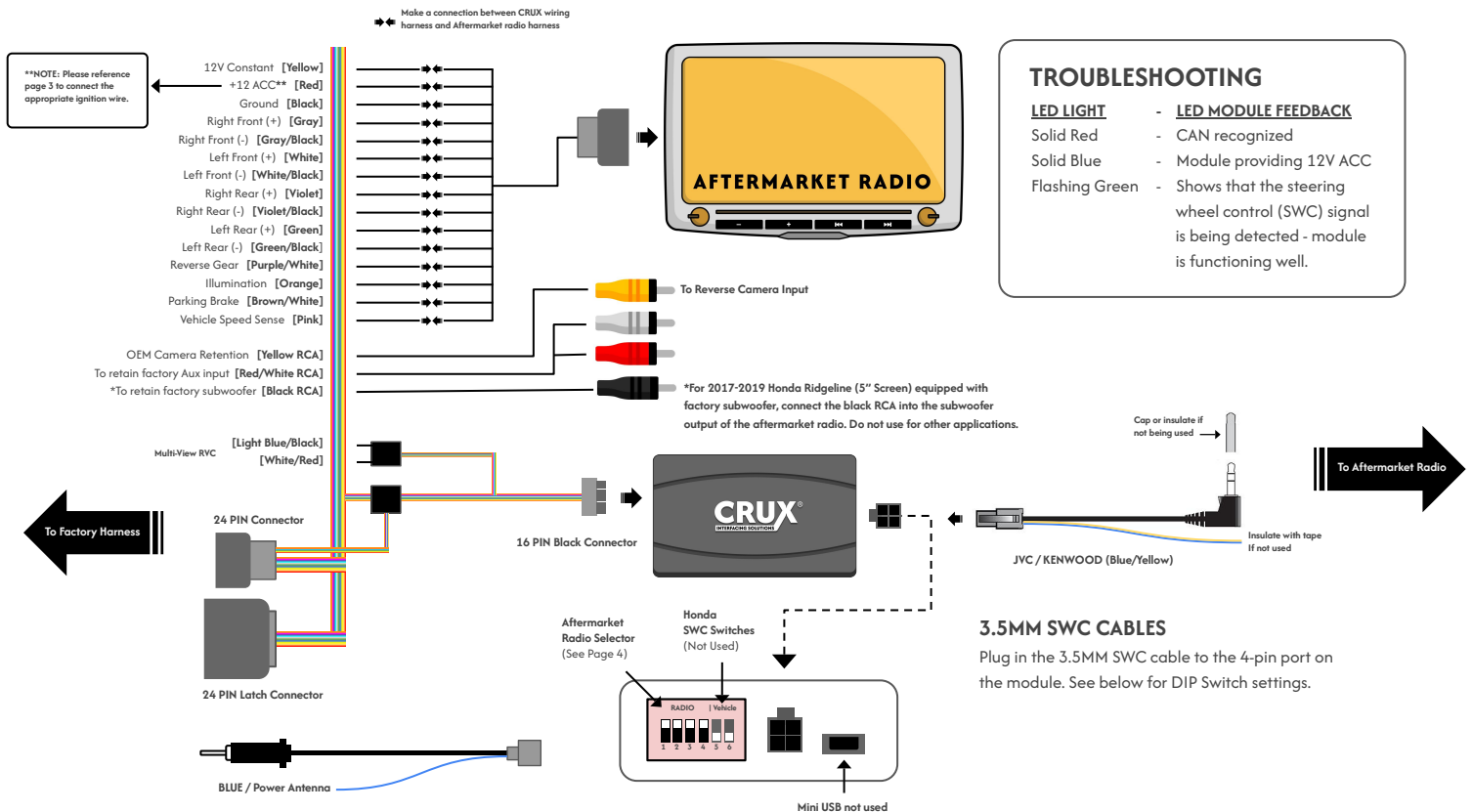

## ALTERNATIVE ACCESSORY POWER TROUBLESHOOTING:

*NOTE: If you are experiencing issues with accessory power from the module, connect the provided alternative power wire to the CRUX connector and then to the aftermarket radio.*



### HARNES VIEW

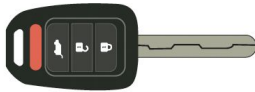

#### For Vehicles with STANDARD KEY

If your vehicle uses a regular key, connect the red accessory wire using the 2-pin female Molex connector to the matching 2-pin male Molex connector as shown in the diagram, then connect the wire to the aftermarket radio.

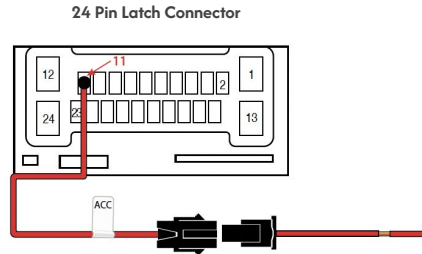

#### For Vehicles with PUSH START ignition

If your vehicle has a push-start button, connect the red/black Ignition IGN wire using the 2-pin female Molex connector to the matching 2-pin male Molex connector as shown in the diagram, then connect the wire to the aftermarket radio.

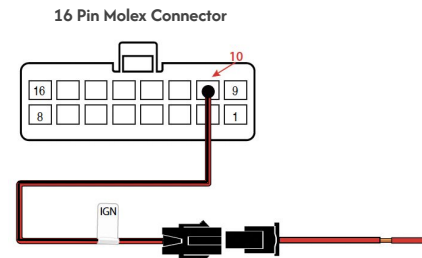

## DIP SWITCH SETTINGS:

### AFTERMARKET RADIO DIP SWITCH SETTINGS:

RADIO BRAND:	DIP#:	1	2	3	4
Atoto, Dual, Fahrenheit, Jensen, Nakamichi		OFF	ON	ON	ON
Pioneer, Power Acoustik, Soundstream		OFF	ON	ON	ON
Blaupunkt, Most off-brand Radio		OFF	ON	ON	ON
Alpine		OFF	OFF	OFF	OFF
Clarion		ON	ON	OFF	OFF
Kenwood		ON	ON	ON	ON
JVC		ON	OFF	ON	ON
BOSS, Old Sony		ON	OFF	OFF	OFF
New Sony (with CarPlay)		OFF	ON	OFF	OFF
SWC Learning Radios*		ON	OFF	OFF	ON
New Boss		ON	OFF	ON	OFF

*NOTE: For Atoto, Blaupunkt, Dual, Fahrenheit, Nakamichi, Power Acoustik, Soundstream, and most off-brand radios. Check the aftermarket radio's manual to see if the SWC buttons need to be programmed  
\* For SWC Learning Radios specific steps are required. Please scan the QR code on the right.*

For aftermarket radios that have wires for SWC connections, cut off the 3.5mm plug on the Crux SWC Cable (option B) and connect the SWC wires as follows:



Note that there are some radios that only have SWC1 and SWC2, in this case "shield" does not need to be connected.

#### SWC TROUBLESHOOTING OPTION



Located internally, need to take plastic casing off module

If Steering Wheel Controls don't work or work properly, please switch internal DIP switch from 3v3 to 5v as shown in picture above.



NOTE:  
DIP Switches  
5-6 are not used



Troubleshooting for SWC Learning Radios

## VEHICLE APPLICATIONS:

YEARS	MAKE	MODEL
2015 - 2018	HONDA	FIT LX (with 5" screen)
2017 - 2019	HONDA	RIDGELINE RT/RTS/Sport/RTL (with 5" screen)
2015 - 2018	HONDA	HR-V LX (with 5" screen)

**NOTE:**

- Does **NOT** support amplified systems.
- Does **NOT** support Rear-Seat Entertainment systems(RSE).
- **NOT** compatible with Factory Navigation systems.

## MULTI-ANGLE REAR VIEW CAMERA:



▶ The Crux SWRHN-62HV retains the factory Multi-Angle Rearview Camera functionality. Use the **FACTORY SOURCE** button on the steering to switch between the available camera views. Follow steps below.



▶ Place vehicle in reverse for **DEFAULT** camera view.



▶ For wide angle view press **SOURCE** button for 1 second.



▶ For top down camera view press **SOURCE** button for 1 second.

## CAMERA TROUBLESHOOTING FOR 2017-2019 HONDA RIDGELINE EQUIPPED WITH 5" SCREENS:

### 2017–2019 Honda Ridgeline with 5" Display:

On harnesses manufactured prior to March 2026, the reverse camera image may not display in certain situations. If this occurs, check the Crux 24-PIN Connector and relocate the RCA video ground (black wire) from Pin 3 to Pin 19.

SWRHN-62HV with **LOT # on module with 03232026 and Up** have been updated and do not require this modification.

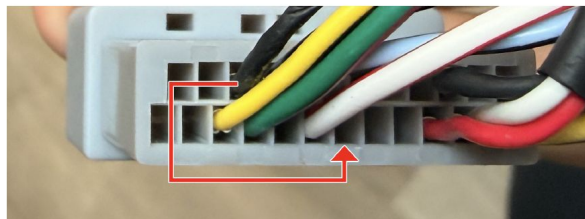
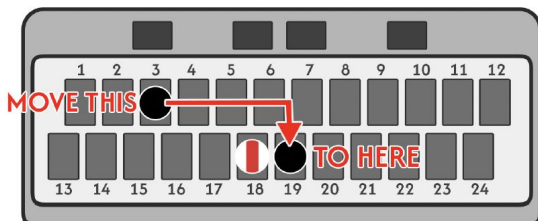

CRUX 24-PIN Connector Wire Side View

## OEM RADIO COMPATIBILITY:

---



FIT LX (with 5" screen)

---



HR-V LX (with 5" screen)

---



RIDGELINE RT/RTS/Sport/RTL (with 5" screen)

---