



SWRGM-49

Radio Replacement Interface with Steering Wheel Control Retention for
GM LAN 29-Bit Vehicles 2006-2015

PRODUCT MANUAL
VER.052626

CONTACT

ADDRESS:

CRUX Interfacing Solutions
21541 Nordhoff St. Unit C,
Chatsworth, CA 91311

PHONE:

(818) 609-9299

E-MAIL:

support@cruxinterfacing.com
sales@cruxinterfacing.com

WEBSITE:

www.cruxinterfacing.com

PRODUCT FEATURES:

- Retains factory features in select GM LAN 29 Bit vehicles while functioning with an aftermarket radio.
- Pre-programmed to retain factory Steering Wheel Controls.
- iPhone Voice Recognition (VR) feature from SWC on select radios.
- Supports Pick Up/End Call, Pick up and Toggle between 1st and 2nd incoming call, AVRCP Track, Seek.
- Supports Bose, non-Bose and Y-91 audio systems.
- Retains chime functions.
- Provides Factory Rear Seat Entertainment Activation. Requires Cable #CRUX2333A (sold separately).
- Retains factory backup camera.*
- Retains factory backup sensors / park assist system.
- EIA color coded wiring for easy installation.

NOTE:

1. Does not retain the factory backup camera on models that show the camera image on the rearview mirror
2. This interface does NOT retain the vehicle's factory OnStar system. If OnStar retention is desired, please use CRUX part # SOOGM-16.
3. This interface is NOT compatible with 2012-2014 SUVs and trucks equipped with factory-installed navigation radios. For these vehicles, please use CRUX part #SOOGM-16W

PARTS INCLUDED:



INSTALLATION DIAGRAM:

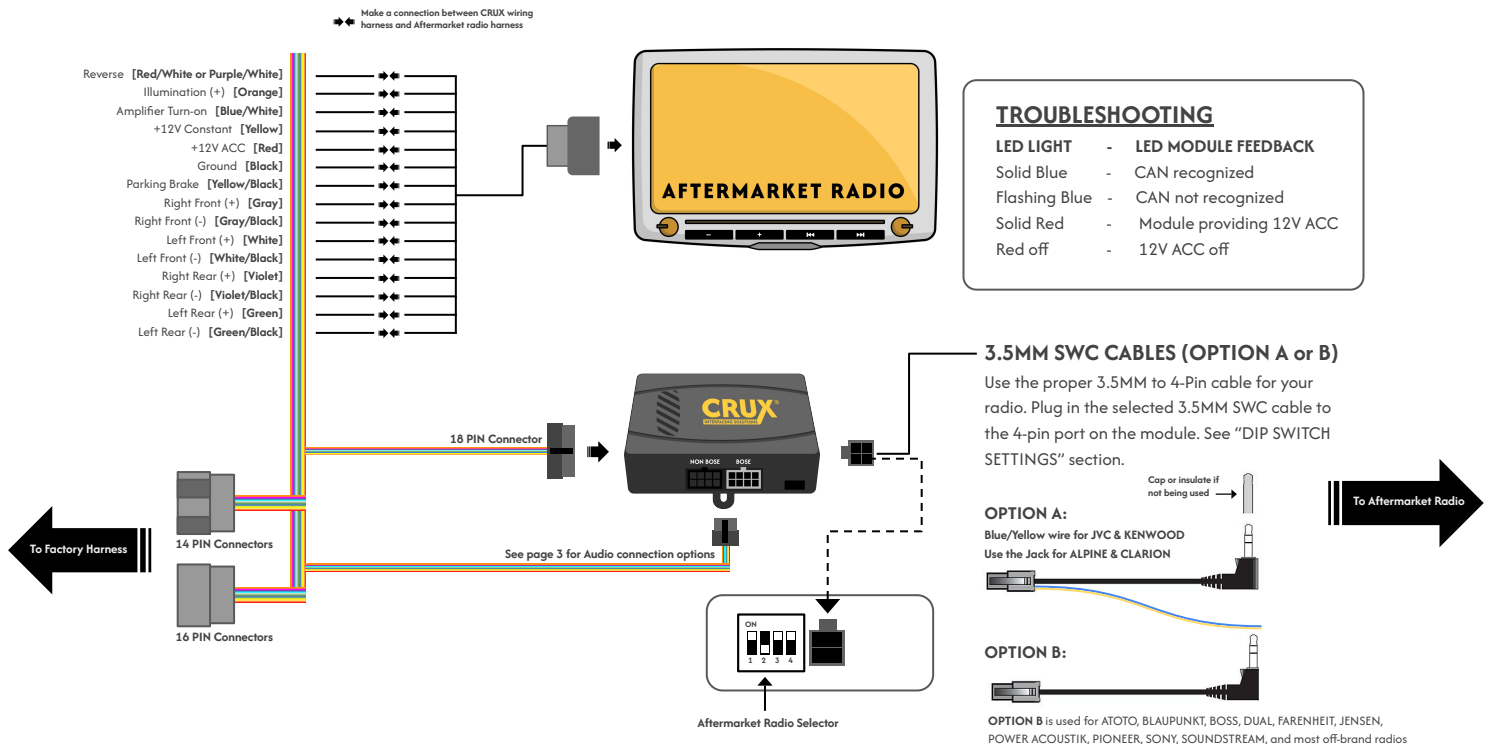

DIP SWITCH SETTINGS:

AFTERMARKET RADIO DIP SWITCH SETTINGS:

RADIO BRAND:	DIP#:	1	2	3	4
Atoto, Dual, Fahrenheit, Jensen, Nakamichi		OFF	OFF	ON	ON
Pioneer, Power Acoustik, Soundstream		OFF	OFF	ON	ON
Blaupunkt, Most off-brand Radio		OFF	OFF	ON	ON
Alpine		OFF	OFF	OFF	OFF
Clarion		OFF	ON	ON	OFF
Kenwood		OFF	ON	ON	ON
JVC		OFF	ON	OFF	ON
BOSS, Old Sony		OFF	ON	OFF	OFF
New Sony (with CarPlay)		OFF	OFF	ON	OFF
New BOSS		ON	OFF	ON	OFF

SWC TROUBLESHOOTING OPTION



Located internally, need to take plastic casing off module

If Steering Wheel Controls don't work or work properly, please switch internal DIP switch from 3v3 to 5v as shown in picture above.



SWC Module
DIP Switch

*NOTE: For Atoto, Blaupunkt, Dual, Fahrenheit, Nakamichi, Power Acoustik, Soundstream, and most off-brand radios. Check the aftermarket radio's manual to see if the SWC buttons need to be programmed
* For SWC Learning Radios specific steps are required. Please scan the QR code on the right.*

For aftermarket radios that have wires for SWC connections, cut off the 3.5mm plug on the Crux SWC Cable and connect the SWC wires as follows:



Note that there are some radios that only have SWC1 and SWC2, in this case "shield" does not need to be connected.



NOTE:

If you have the previous generation hardware with 3 DIP switches, please scan the QR code below and refer to the Aftermarket Radio DIP Switch Settings guide.

SELECTING THE AUDIO SYSTEM:

If the vehicle is equipped with an amplified audio system, the SWRGM-49 has a built-in audio level adaptor that outputs the proper audio level from the aftermarket radio to the factory amplifier. To use this feature, plug in the male 8-PIN connector on the SWRGM-49 harness to the GRAY female 8-PIN connector on the SWRGM-49 module. The module is also labeled "BOSE" and "NON BOSE" to avoid confusion. (see image for reference)

If vehicle is NOT equipped with a factory amplified system, plug-in the male 8-PIN connector the the BLACK female 8-PIN on the SWRGM-49 module.

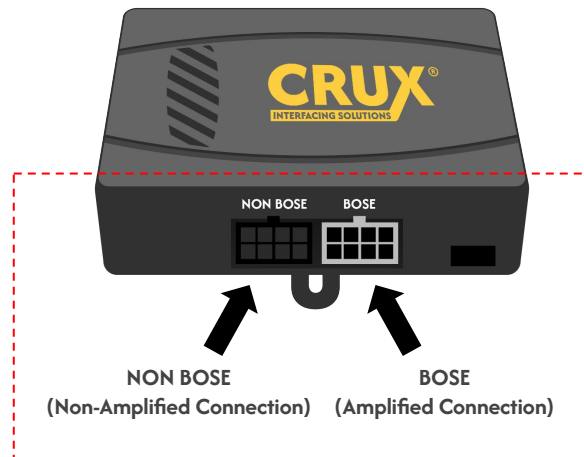

CHIME VOLUME ADJUSTMENT:

The SWRGM-49 has a potentiometer to adjust the chime volume. It is set at the half way by default. To adjust the volume, simply use a suitable screwdriver and turn the potentiometer clockwise to increase the volume and counter-clockwise to decrease the volume.

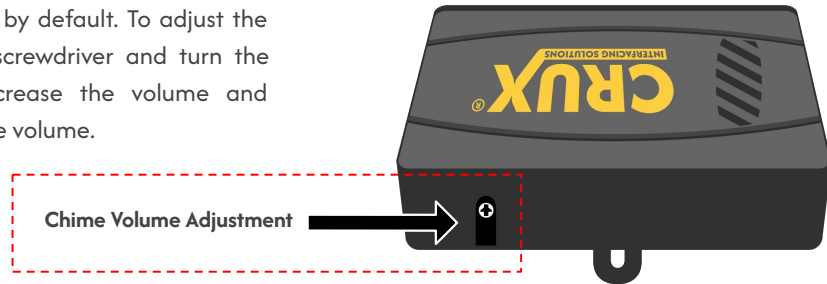

BACKUP CAMERA CONNECTION:

You can retain the factory back-up camera by using the CRUX 2543 harness included in the kit.

1. Connect the 16-PIN back-up camera harness to the vehicle's 16-PIN factory backup camera connector.
2. Connect the Yellow video RCA to the new aftermarket radio camera input.
3. Test the video feed before installing the radio back into the dashboard.

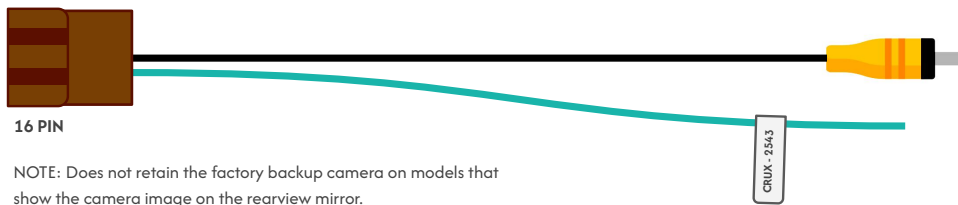

NOTE: Does not retain the factory backup camera on models that show the camera image on the rearview mirror.

VEHICLE APPLICATIONS:

YEARS	MAKE	MODEL	YEARS	MAKE	MODEL
2008-2017	BUICK	Enclave	2007-2016	GMC	Acadia
2006-2011	BUICK	Lucerne	2017	GMC	Acadia Classic
2007-2014	CADILLAC	Escalade	2008-2017	GMC	Savana**
2007-2009	CADILLAC	SRX	2007-2013	GMC	Sierra 1500-3500 Pickup*
2007-2013	CHEVROLET	Avalanche*	2007-2014	GMC	Yukon*
2007-2008	CHEVROLET	Equinox	2008-2009	HUMMER	H2
2008-2016	CHEVROLET	Express Van**	2007-2009	PONTIAC	Torrent
2006-2013	CHEVROLET	Impala / Impala SS	2007-2009	SATURN	Outlook
2014-2016	CHEVROLET	Impala Classic	2008-2009	SATURN	Vue
2006-2007	CHEVROLET	Monte Carlo	2007-2008	SUZUKI	XL7
2007-2013	CHEVROLET	Silverado 1500-3500 Pickup*			
2007-2014	CHEVROLET	Suburban*			
2007-2014	CHEVROLET	Tahoe*			
2009-2014	CHEVROLET	Traverse			

1. *NOT compatible with 2012-Up SUVs/Trucks that are equipped with factory-installed Navigation radios. Use part #SWRGM-49A instead.
2. **NOT compatible with Express and Savana vans that are powered by a diesel engine.